

**Operators & Service
Manual
XL4
*automation***

EVI PRO AUDIO GROUP
Klark Teknik Building,
Walter Nash Road, Kidderminster,
Worcestershire DY11 7HJ,
England

Tel:(01562)741515 Fax:(01562)745371

MIDAS

XL4 Automation system

System operation

while every effort has been made to ensure it is accurate, there may be changes dependent on the software version. This has been written for Version 25.A

Should you find an error, or you find a section ambiguous, please let MIDAS know so that we may correct the problem.

Information about this manual

In this document the following colours have been used to aid the text:

Descriptions of what can be seen on the Alpha-numeric displays are in green, such as 'OVERSTORE'.

When a button is referred to, its name is in blue, such as 'STORE'.

Functions or operation names are in red, such as 'SCENE NAME'.

Warnings and important notes have their headings in magenta, such as 'WARNING'.

Contents

Introduction.	5
Automation system overview.	5
The Central control unit.	6
Operating the system.	7
Input fader mode control.	7
System Start Up	7
Unlock The Automation System	7
Scene Storage	8
Scene Recall	8
System menu	9
Unlock	9
Lock	9
Chmidiout	10
Chmidin	10
Automidi	10
RSLink	10
Faders	10
Mutes	10
Matrix	10
Contacts	10
XL4 Size	11
Mem Size	11
Format	11
Test 1	11
Test 2	11
Test 3	11
Test 4	11
Open	11
Restrict	11
Totclear	11
Total Clear Format Procedure	12
Store Menu	15
New Scene	15
Overstoring	16
X-FADE (Crossfade).	16
Expand	16
Insert.	16
Delete.	16
Copy.	16
Edit.	16
Edit scene name.	16
Edit MIDI In	17
Midi Clear	17
Edit midi Out	17

Contents Cont.

Memory menu.	18
Toggle	18
Internal.	18
External.	18
Copy all.	18
Clear all.	18
Alternate Buttons	19
Using the system - general hints and tips.	19

Introduction.

Automation system overview.

The MIDAS XL4 is an 'intelligent' live mixing console. It utilises microprocessor technology to provide the operator with unprecedented features for a live console, whilst remaining easy to use and retaining the familiar look of a normal console.

The update speed of the MIDAS XL4 automation was a high priority of the system design, the entire console is capable of updating itself over fifty times a second. Thus the delay between pressing the 'RECALL' button and the desk update is negligible.

Some sound engineers harbour concerns about giving control of a sound system over to computers, in the case of the MIDAS XL4 these concerns are unfounded. For one thing, the MIDAS XL4 is a 'computer assisted' console. Most of the audio functions may be controlled without the aid of microprocessors, and all audio functions may be controlled without the central control CPU.

With the exception of the central controller CPU, the microprocessor chips used are 'single chip micro's' or 'microcontrollers'. The CPU, program memory, RAM, data converters and timers are all housed in a single chip. This gives the utmost in reliability as the 'computer' itself is protected from the outside world by it's input/output ports.

Fifty microprocessors (in a standard 48 input console) split the workload, resulting in high speed operation and also providing the large degree of protection required for live performances. Should one microprocessor 'fall over' the others will continue to operate normally.

In addition, the system has been designed in such a way that if a microprocessor does fail, the audio circuits controlled by that unit will usually remain active in the state last recalled. The chances of a microprocessor failing in such a way as to reconfigure its audio control circuits are extremely remote. The most likely indication that a microprocessor has failed will be that it fails to respond to the central control CPU. The audio circuits will continue to work.

Important controls such as the MUTE switch, whilst they can be over-ridden by microprocessor control, will work without the intervention of a microprocessor.

Each input channel has its own microprocessor, the VCA master section has one and the final microprocessor is in the central control section.

All the microprocessors are located in the fader bay of the XL4. No audio passes through the fader bay, allowing a high degree of immunity to digital breakthrough to be achieved.

The use of multiple processors also means that the software, instead of being one large program, is broken up into a number of small programs which are easier to test and debug, minimising the chances of software problems.

The Central control unit.

The MIDAS XL4 Automation is controlled from the central control CPU mounted to the right of the VCA Master faders.

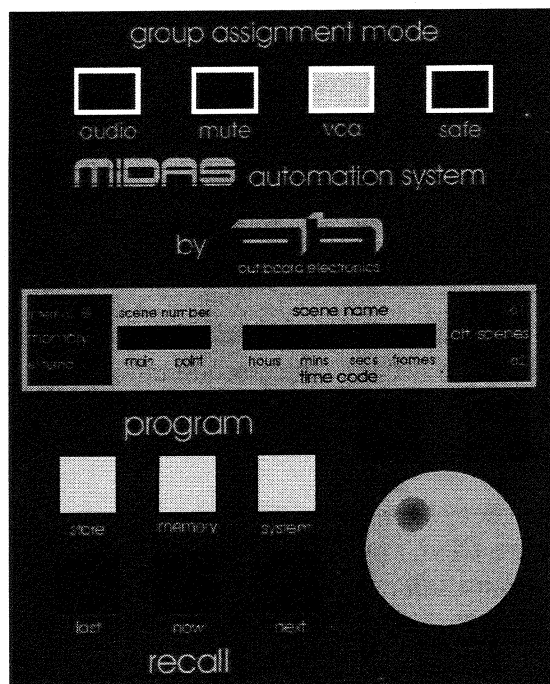

The top four switches, labelled 'AUDIO', 'MUTE', 'VCA' & 'LOCK' are not directly part of the central control CPU, these switches directly control the operating mode of the input fader automation. (See Input fader mode control, later).

The central controller CPU has been developed by OUTBOARD ELECTRONICS Ltd. in conjunction with MIDAS. The operation of the MIDAS XL4 Automation system is based on the control system used on the OUTBOARD ELECTRONICS SS20 Moving fader system. Many operators used to the SS20 will find operating the MIDAS XL4 Automation system very familiar.

Control of the system is achieved with eight buttons and a 'jogwheel'. Operator feedback is done with two displays, a four character 'scene number' display and an eight character 'scene name' display.

Auxiliary functions are accessed through a series of menus.

The main 1 Meg of internal memory is battery backed up and may also be downloaded on to a memory card.

Operating the system.

Input fader mode control

The top four switches of the central control unit, labelled 'AUDIO', 'MUTE', 'VCA' & 'LOCK' directly control the operating mode of the input fader automation.

With the 'AUDIO' mode enabled, the fader bay switch bank controls the audio group routing. Only switches 1-8 are used. Switches 9 & 10 are used to trigger a input moving fader calibration on the input channel (when fitted, if no moving fader is fitted the function will time out). To use this function press switch 9. The LEDs associated with switches 9 & 10 will flash. This indicates that the clear function is 'armed'. Pressing switch 10 will clear the channel.

If switch 9 is pressed, arming the calibrate function, and it is not desired to calibrate the channel, pressing switch 9 again will disarm the clear function.

With the 'MUTE' mode enabled, the fader bay switch bank controls the automute assignments. Only switches 1-8 are used for automutes. Switches 9 & 10 are used for the channel clear function.

The channel clear function resets all computer controlled settings on that channel to off. To use this function press switch 9. The LEDs associated with switches 9 & 10 will flash. This indicates that the clear function is 'armed'. Pressing switch 10 will clear the channel.

If switch 9 is pressed, arming the clear function, and it is not desired to clear the channel, pressing switch 9 again will disarm the clear function.

With the 'VCA' mode enabled, the fader bay switch bank controls the VCA assignments.

When the system is 'locked' (with the 'LOCK' switch illuminated) the three operating modes may be called up, allowing the state of the switches to be seen, but the switches will not operate. This is to prevent accidental operation of the fader bay switches.

SystemStart up

Following power up, the alpha-numeric display will briefly show the software release version, followed by 'READY'. This indicates that the initialisation is complete and the system is ready for use.

The system powers up in the 'locked' state. In this state scenes may be recalled but not stored. All functions which modify the stored data are disabled until the system has been unlocked.

Unlocking The System

To unlock the system after start up the following procedure must be followed. Press the **SYSTEM** button and **UNLOCK** will be displayed in the right hand screen. Press the **YES** button and the left hand window will change to read 1200, using the jog wheel alter this screen until the correct password is displayed. This password is found on the insert provided with this manual or can be obtained from Midas.

Scene storage

Storing scenes may only be done when the system is unlocked.

To store a scene, first display the position you wish to store the scene in on the left hand window by using the jog wheel. Scene 0000 is a preset scene and can not be overstored. Once the required position is displayed press the '**STORE**' button. The display will respond with '**NEW**', if the scene does not yet exist or '**OVERSTORE**' if the scene does exist.

Following a scene store operation, the scene number is incremented by 1 or 0.1 depending on whether the scene was expanded previously.

Scene recall

Recalling scenes is achieved using the '**LAST**', '**NOW**' and '**NEXT**' buttons, and also using the jogwheel.

Pressing the '**NEXT**' button causes the system to step to the next scene number in memory and recall it to the console. After the last scene has been recalled, pressing '**NEXT**' will cause the display to show '**END**' and no other operation will occur.

Pressing the '**LAST**' button causes the system to step to the previous scene number in memory and recall it to the console. After the first scene has been recalled, pressing '**NEXT**' will cause the display to show '**START**' and no other operation will occur.

Pressing '**NOW**' will recall the scene number currently shown in the left hand section of the display. This number may be adjusted using the jogwheel.

When the system is locked the jogwheel will only use the numbers of scenes that exist in memory.

No operations other than recall are available while the system is locked.

When the system is unlocked the jogwheel adjust the scene number in increments of one whether the scene exists or not. Attempting to recall a scene number which does not exist will result in the message '**EMPTY**'.

System menu.

To call the system menu, press the 'SYSTEM' button. The display will show 'SYSTEM' and the 'SYSTEM', 'NO' and 'YES' buttons will flash.

The jogwheel may then be used to scroll through the system options.

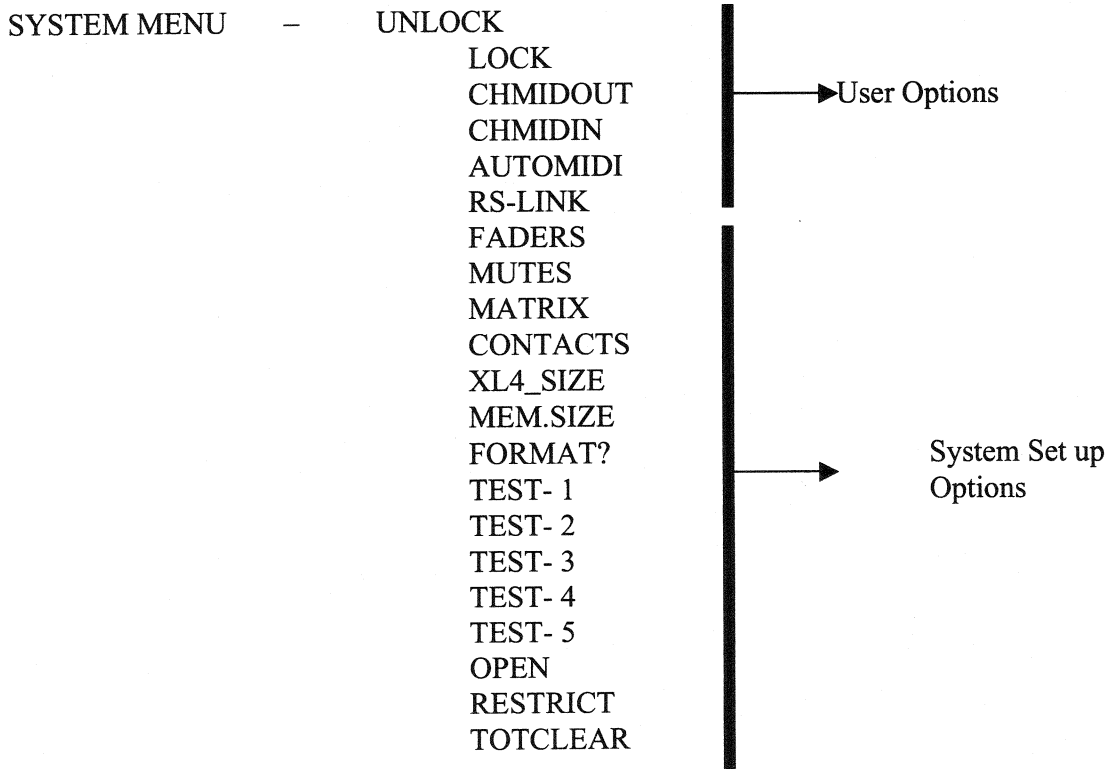

UNLOCK

To unlock the system, press the 'YES' button while the display is showing 'UNLOCK'. The jogwheel may then be used to adjust the password number shown in the left section of the display.

When the correct password number is shown, press 'YES'. If the number is accepted the display will briefly show 'OK'. This indicates that the system is unlocked. The display will then return to showing the title of the current scene.

If the display returns directly to the scene title without showing 'OK' then the number has not been accepted and the system is still locked.

LOCK

To lock the system, rotate the jogwheel until the 'LOCK' option is displayed. Pressing 'YES' will then lock the system, this will be indicated by the display briefly showing 'DONE'. The display will then return to showing the title of the current scene.

CHMIDOUT

This option allows the output MIDI Channel to be selected. To set the channel number, press the 'YES' button while the display is showing 'MIDI CH'. The jogwheel can then be used to select the required channel. When the required channel number is displayed, press the 'YES' button to enter it.

CHMIDIN

This option allows the input MIDI Channel to be selected. This is the channel down which program changes can be sent that the XL4 will respond to when set up in the edit menu, see store menu. To set the channel number, press the 'YES' button while the display is showing 'MIDI CH'. The jogwheel can then be used to select the required channel. When the required channel number is displayed, press the 'YES' button to enter it.

AUTOMIDI

This function when enabled automatically places a midi out message with every scene stored (0 to 99 only). This message is sent out on the midi channel selected using the MIDI CH selection. For example if scene 0100 is stored after automidi is enabled, when recalled a program change one will be sent from the midi out port on the midi channel selected in MIDI CH.

RS-LINK

This function allows you to enable and disable the RS link on the rear of the console (RS232-2). Pressing the 'YES' button when this is displayed in the left hand display will then allow you to choose YES or NO using the jog wheel. Once you have chosen pressing 'YES' will save your choice and drop you back out of the menu. This function is used when 2 XL4s are linked, enabling the one consoles automation to follow the others. You can either make one the consoles a master slave combination by disabling the RS232 in one console or control the recall of the automation from either console if they are both enabled.

FADERS

This option is not used. However if the memory has been corrupted for some reason (during servicing for example) this value should be set to zero. This procedure is described in the total clear and format procedure.

MUTES

This option is not used. However if the memory has been corrupted for some reason (during servicing for example) this value should be set to zero. This procedure is described in the total clear and format procedure.

MATRIX

This option is not used. However if the memory has been corrupted for some reason (during servicing for example) this value should be set to zero. This procedure is described in the total clear and format procedure.

CONTACTS

This option is not used. However if the memory has been corrupted for some reason (during servicing for example) this value should be set to zero. This procedure is described in the total clear and format procedure.

XL4 SIZE

This number should be set to 48. However if the memory has been corrupted for some reason (during servicing for example) this value should be set to zero. This procedure is described in the total clear and format procedure.

MEM SIZE

This number should be set to 31. However if the memory has been corrupted for some reason (during servicing for example) this value should be set to zero. This procedure is described in the total clear and format procedure.

FORMAT

Once the system settings have been entered, this option is used to format the memory ready for use. This is done by pressing 'YES' when the display is showing 'FORMAT'.

Test 1

This sets the speed of Test 2 and 3

Test 2

This cycles through the scenes at a speed set by Test 1.

Test 3

This is a continuous read/write test as a speed set by Test 1.

Test 4

This is a system memory test, the automation control system will write and read to each bit of memory individually and check for any errors. This test is extremely time consuming and special equipment is needed to see any results as there is no decipherable error messages are shown on the display if a fault is found.

WARNING!

During the test modes, the motorised faders should be disabled using the 'ISOLATE' switch. Allowing the faders to attempt to keep up with the test function for long periods may damage the servo drivers.

OPEN

This allows you to enter the password which then enables access to the RESTRICT function in the menu. To access this press the YES button the left hand screen will then change to read 3200, using the jog wheel enter the correct password and press the YES button. This password is found on the insert provided with this manual or the separate password pdf provided.

RESTRICT

This function is only accessible after the correct password has been entered into the OPEN option. This function allows Midas to look at the last 8 operations of the automation control system and awspaced in for software debugging purposes.

Total Clear

This function allows you to do a complete low level format of the automation control system memory. This procedure is shown next : **WARNING** if this procedure is carried out all user information will be lost.

Total Clear and Format Procedure

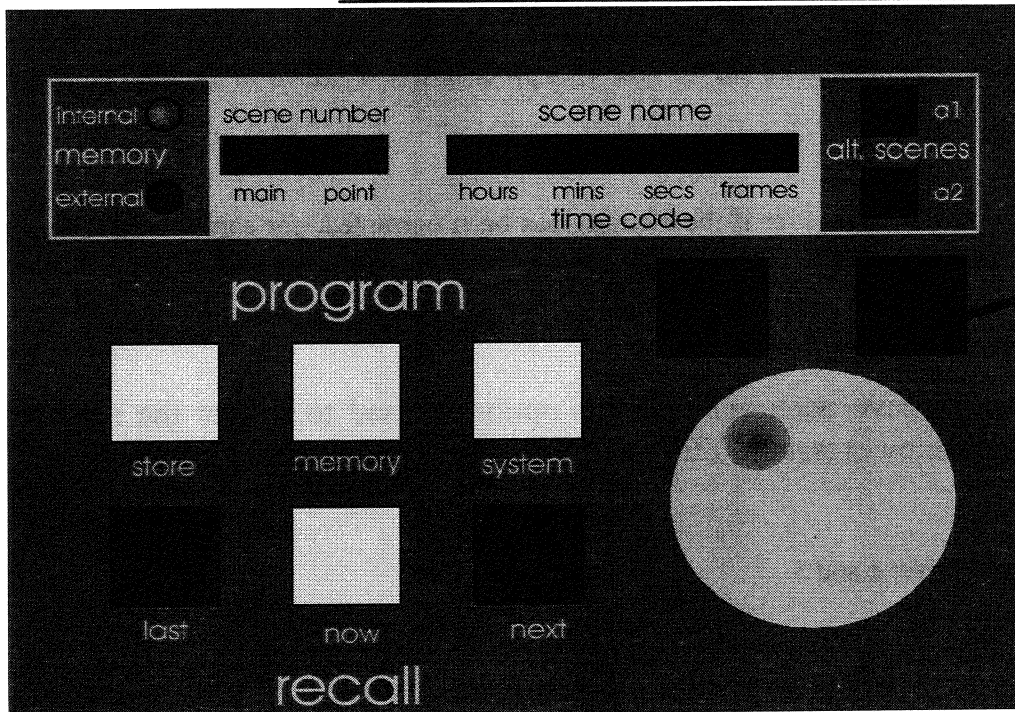

CONFIRM button

TOTAL CLEAR AND FORMAT PROCEDURE

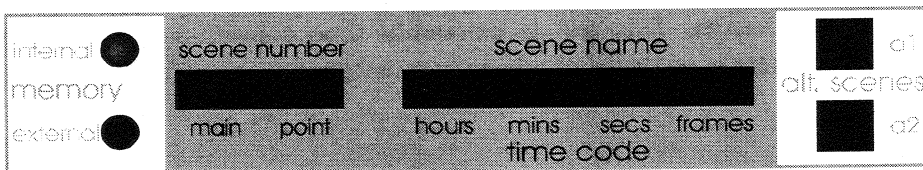

Press SYSTEM button on CPU panel
Scroll to TOT CLEAR and press CONFIRM (large green button)

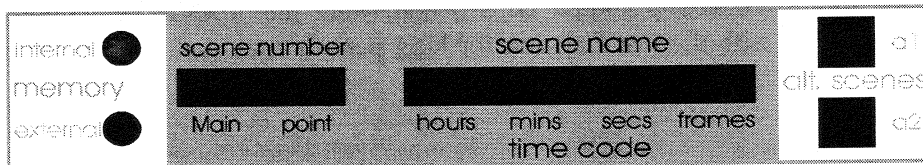

Display prompts R U SURE, press CONFIRM

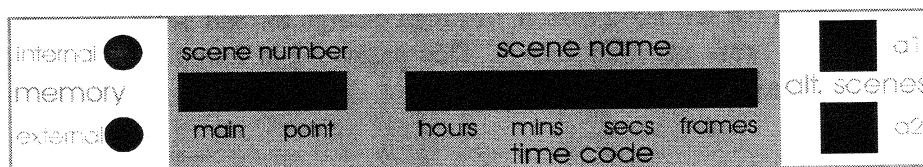

Then at PASSWORD? prompt, scroll to 2345 and CONFIRM

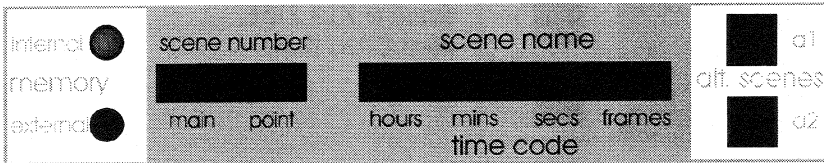

Display prompts TOTAL CLEAR, then WAIT, then DONE

Reset the console by turning power off/on or by pressing the reset button within the vent below the card socket.

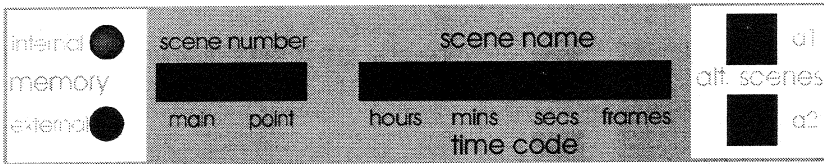

Press SYSTEM, Scroll to FADERS, Press CONFIRM

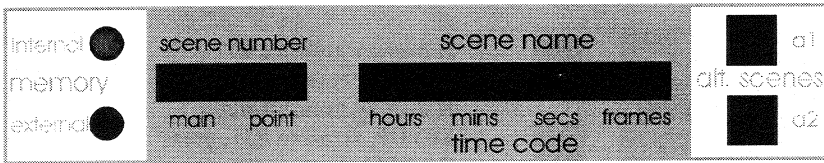

Display prompts 2222 PASSWORD?

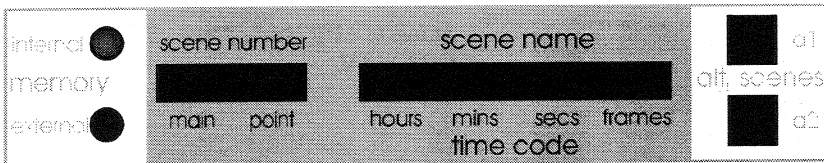

Scroll to 2345, Press

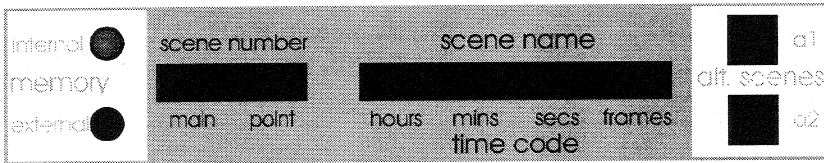

Display prompts FADERS then 000 SETUP, Press CONFIRM

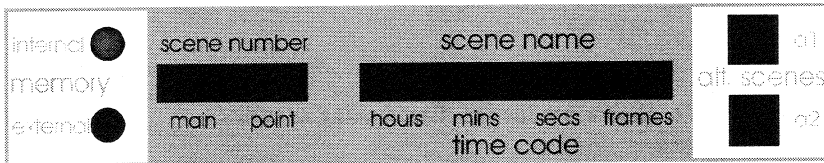

Scroll to MUTES, Press CONFIRM, display prompts 000 SETUP, press CONFIRM

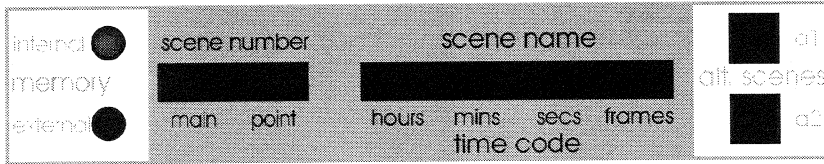

Scroll to MATRIX, Press CONFIRM, display prompts 000 SETUP, press CONFIRM

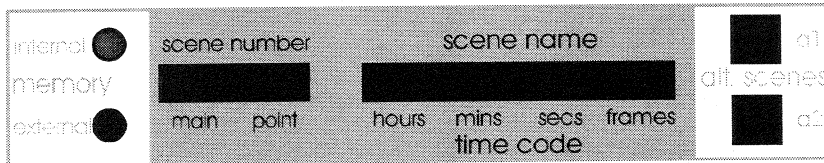

Scroll to CONTACTS, Press CONFIRM, display prompts 000 SETUP, press CONFIRM

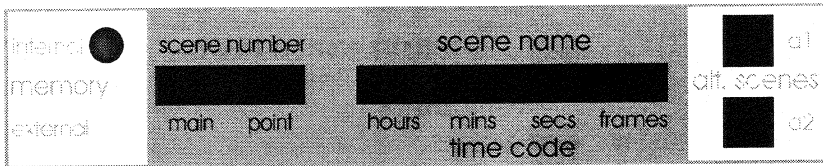

Scroll to XL4 SIZE,
press CONFIRM

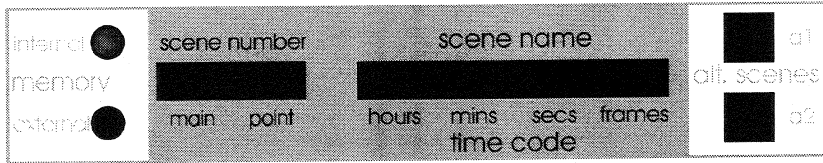

If display prompts 048
SETUP, press CONFIRM
If display prompts 000
SETUP, scroll to 048, press
CONFIRM

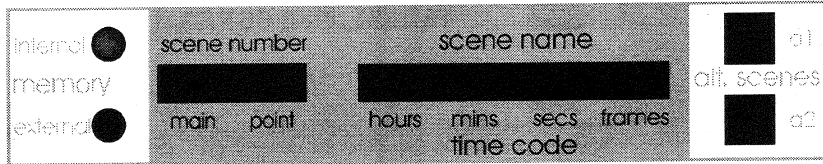

Scroll to MEM SIZE, Press
CONFIRM

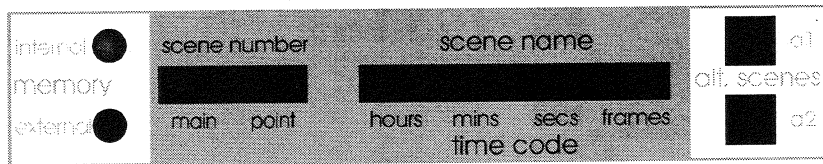

If display prompts 031
SETUP, press CONFIRM
If display prompts 000
SETUP, scroll to 031, press
CONFIRM

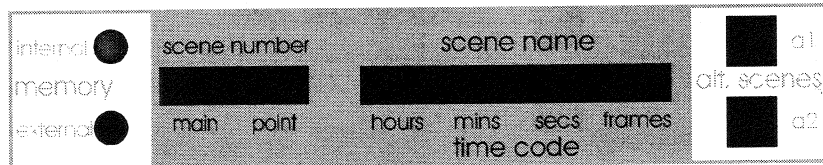

Scroll to FORMAT, Press
CONFIRM

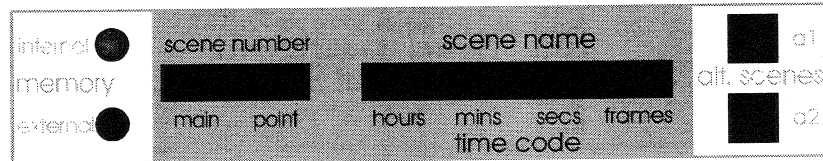

Display prompts WAIT,
then DONE, then displays
START

It is advisable to repeat this procedure at the beginning of each new production, first making sure that you have saved your data to your external memory data card.

Store Menu

There are 2 possible menus available when the 'STORE' button is pressed dependent on whether you are storing a new scene or editing an existing one.

If no scene is present in the location you are trying to store to (displayed in the left hand window) the menu you may access is shown below.

```
STORE -   NEW
          X-FADE
```

If a scene has previously been stored in the location you are trying to store to (displayed in the left hand window)

```
Overstore -  OVERSTORE
             X FADE
             EXPAND
             INSERT
             DELETE
             EDIT -
```

```
SC.NAME
MIDI_IN -----  Program Number ***
Midi CLR
MIDI OUT  -----  1-Ch No-   Prog
                                     Note on
                                     Note Off
                                     ↓
                                     8-Ch No-   Prog
                                     Note On
                                     Note Off
                                     9- Exit
```

New scene.

If the scene number does not yet exist, the display will respond with 'NEW'. To create the scene press 'YES'. The scene will be created and the current status of the console will be stored in it.

The scene number may be adjusted using the jog wheel before pressing 'STORE'. The scene number may be adjusted before or after setting the desired console configuration.

Should 'STORE' be pressed in error, the 'NO' button will exit the procedure without taking any further action.

Overstoring

If the scene number does exist, the display will respond with 'OVERSTORE'. To update the scene press 'YES'. The existing scene will be replaced with the current status of the console.

Pressing 'NO' will abandon the store procedure without taking any further action.

X-FADE (Crossfade).

This allows the faders crossfade speed to be adjusted from 0.5 to 10 seconds in 99 equal steps.

The speed is set using the jogwheel, pressing 'YES' then stores the scene.

WARNING When editing the crossfade speed it is important to note that the speed you leave set in the left hand window will be applied to any scene stored or overstored after.

Expand.

This is used to set the scene number increment value to use the decimal places. This is used when the number of expected scenes is greater than 99. It causes the auto-increment to step in 0.1 steps instead of 1.

Insert

This option allows extra scenes to be inserted between existing scenes. To insert a new scene dial up the number of the scene that you wish to come **after** the new scene. The scene will be inserted **before** the scene displayed.

The new scene will be given the number of the previous scene plus point five.

Once an extra scene has been added, decimal place numbered scenes will be accessible between the previous scene with a whole number and the next scene with a whole number.

This can occur to two levels, that is scenes may be stored between decimal place numbered scenes using the 'hundredths' digit as well.

Delete

This option is used to delete the current scene from memory. There is currently no way to restore a scene once it has been deleted, so this function should be used with caution.

Edit

EDIT calls up a further sub-menu for editing facilities.

Sc. NAME

To enter or edit a scene name, dial up this option and press 'YES'.

The character in the left hand position of the scene name display may then be adjusted using the jogwheel. When the desired character is visible, press 'YES' again and the character will be stored. The next character on the right may then be adjusted. Continue until all eight characters have been entered, when the normal system operation will resume. To leave a character as it is, press 'YES' without moving the jogwheel.

MIDI IN

This function allows you to edit the midi program change that the scene will be recalled by when received. The XL4 will monitor the midi channel set in the CH.MIDI in located in the SYSTEM Menu.

MIDI CLR

This function allows you to clear all the midi information associated with the particular scene you are on.

This function is used to set up a MIDI message which will be transmitted whenever the scene containing the message is recalled.

MIDI OUT

This function allows you to edit the 8 possible midi out messages the console can send out when a scene is recalled.

To program the multiple-midi outputs the following procedure must be followed.

1/ Press *STORE* and scroll the screen using the jogwheel until *EDIT* is seen, press the **YES** button.

2/ Scroll the screen until *MIDIOUT* is seen, press the *YES* button.

3/ You may now select one of the eight midiout messages for editing. This may be done using the jogwheel. When the required message number is displayed in the left hand window press the **YES** button.

4/ In the left hand window the midi channel the message is sent out on will be displayed. This may be changed using the jogwheel, when the required channel is selected press **YES**.

5/ Using the jogwheel you may choose one of the following to edit in the right hand display *NOTEOFF*, *NOTEON*, *PROGRAM* and *CLEAR* when the required parameter is displayed press **YES**. *CLEAR* will delete that particular message from the group sent with that scene change.

6/ The chosen parameter may then be changed using the jogwheel and selected by pressing **YES** when the required value is displayed.

7/ When all the midi out messages have been edited to exit scroll through the message list until *9 EXIT* is displayed and press **YES**.

NB: This Function edits the Midi information for the last scene recalled using the *Now*, *Next* or *Last* button.

Memory menu

Memory – Mem Tog

- Internal
- External
- Copy All
- Clear All

Mem Tog (Memory Toggle)

This allows you to swap from the memory you are currently working on to other. For example if you are working on Internal memory mode choosing YES to Mem Tog will switch over to External memory.

Internal

This setting sets the system operation to operate with the central control unit's internal memory.

External

This setting sets the system operation to operate with the RAM card memory .

Copy all

This function copies the data to and from the RAM card.

If INTERNAL memory is active, the data will be copied from internal memory to the RAM card.

If EXTERNAL memory is active, the data will be copied from the RAM card to the internal memory.

Clear all

This function clears the data in the memory or RAM card.

If INTERNAL memory is active, the data will be cleared from internal memory .

If EXTERNAL memory is active, the data will be cleared from the RAM card.

WARNING!

Use this function with care! Although future software releases may feature an UNDO function, the current software does not. Once erased there is no way to retrieve the data unless you have saved it to a RAM card which has been kept somewhere safe.

Alt Scene Buttons A1 and A2

These buttons allow the recall of a scene assigned to the switch with a single button push. To assign a scene to either **ALT1** or **ALT2**, recall the scene you wish to assign. Press the **STORE** button, the right hand screen will now read either **NEW** or **OVERSTORE**. Press the **ALT** button that you wish to assign the scene to, the screen will read **OK**. The scene will now be recalled when ever that **ALT** button is pressed. To place a different scene to the button follow the above procedure and the new scene will automatically be overstored to the **ALT** button pressed.

Using the system - general hints and tips.

Setting up a console can be a laborious process, setting it up separately for multiple scenes could be worse!

Make use of the facilities to minimise the work. If you have already programmed in a scene which is similar to the one you wish to create, **RECALL** it, make the required alterations then dial up the number of the new scene you wish to create and **STORE** it.

Backing up.

At the end of a rehearsal session it is good practice to save the data entered to the RAM card. By using three or four RAM cards and rotating them you will always have the last three or four sessions saved ready to be reloaded in an emergency.

XL4 AUTOMATION CIRCUIT DESCRIPTION.

1. Introduction.

The XL4 audio path is totally analogue however many analogue functions are under digital automation control. The automation system is housed in the fader tray along with the VCA faders and their DC control systems. The interface between analogue audio and digital control has been carefully designed to eliminate interference between the two systems. This is achieved by mechanical and electrical segregation of analogue and digital signals. The automation system has been designed in conjunction with "OUTBOARD ELECTRONICS LIMITED" whose motorised faders are fitted to the master VCA's and are available as an option on all input VCA faders.

The automation system is split into 3 main sections:-

The 443 Automation central controller and memory store.

The 403 Input VCA fader blocks (6 off)

The 413 Group VCA fader block (and it's active mother board XL458)

2. Automation Central Controller.

The 443 automation central controller is used as a memory store and as an interface between the operator, the external control ports and the rest of the automation system. It also provides the automation system master clock and controls the reset line to the rest of the automation system.

The 443 automation central controller is constructed from 6 printed circuit boards. 4 of them are attached to the front panel and can be removed as one piece for servicing; the remaining 2 are the automation link mother board and ram card board which are largely passive and are not readily removed.

The top board is the SS3 key pad and display which monitors the jog wheel and switches as well as providing control for the leds and displays. It is connected directly to the microprocessor board below.

The next board is the automation switch sub-board which controls the "audio", "mute", "VCA" and "lock" master switches. These provide a coded output to the input VCA fader boards via the TL0, TL1 and TL2 control lines.

The third board is the microprocessor board which is Z80 based and provides the heart of the system. All ports, buffers and other peripheral devices are housed on this board; it communicates to the rest of the console primarily via buffered address and data lines. These are distributed by the automation link mother board and a series of ribbon cables.

The last board is the memory board which houses the memory for the microprocessor. This should NEVER BE DISCONNECTED from the microprocessor board unless ALL MEMORIES have been saved to another medium. Disconnection of this board will result in memory corruption and the console will need to be re-formatted before it can be used again. The procedure for reformatting the central controller is given in the XL4 Automation Functional Description under the System Menu. A password is required to do this which is 2345.

3. Input VCA Fader.

The 403 input VCA fader block is made up from 1 decode board and 8 VCA fader boards.

The decode board is mechanically attached to 8 fader boards via multi-pin connectors. It is used primarily to decode the address lines from the automation central controller and produce channel select lines for each fader board. There are 6 of these used in the 48 input frame and they are all individually coded for their position in the frame via jumper links.

The codes are as follows:-

<u>Position in frame</u>	<u>Jumpers fitted to JP1 (viewed from front of console)</u>			
1-8	1	1	1	0
9-16	1	1	0	1
17-24	1	1	0	0
25-32	1	0	1	1
33-40	1	0	1	0
41-48	1	0	0	1

The decode board is also used as a back plain to distribute some of the bussed signals from the automation central controller, and as power distribution and filtering for the motorised fader option.

The input VCA fader board uses surface-mount technology, and because of this there are few sections of the pcb that can be serviced without specialised equipment. In the event of a fault it is recommended that a replacement board is fitted and the faulty board returned to MIDAS for repair.

The exceptions to this are the leds and switches which may be worked on without specialised equipment.

In addition, the fader board uses a four-layer pcb, so care should be taken when soldering not to damage the plated-through-holes as any damage to these could be irreparable.

The fader board uses a Hitachi H8/327 microcontroller as the core of the fader control circuitry. Most of the complex operations are performed by this chip internally.

The external functions may be split up into the following sections:-

Microcontroller support circuits.

Microcontroller I/O ports.

Main CPU interface circuits.

Automute circuits.

VCA control circuits.

Motorised fader and analogue circuits.

Microcontroller support circuits.

Reset, which is active low, is generated by the central control unit on power up. It may be overridden using the RESET switch which is mounted on the Automation link mother board. This switch is available through one of the ventilation holes in the front of the console. It has been made difficult to access deliberately to avoid inadvertent operation. Reset is also activated by a PSU failure. The fail detect signal will place the system in reset before the 5 volt rail drops to avoid corruption of the RAM.

The NMI (Non Maskable Interrupt) line is not used and is pulled high by a 10K resistor

The 6 MHz system clock is generated by the Outboard Electronics Central control unit. It is buffered by two 74HC14 inverters and fed into the XTAL and EXTAL inputs to override the microcontrollers internal clock generator circuit. All MCUs are synchronised to the same clock. This eliminates any possibility of beat frequencies being generated, which could happen if separate clocks were used for each MCU. In addition, synchronising the clock allows the data transfer sequence to be precisely timed.

The mode input pins MD0 and MD1 are both pulled high by 10K resistors. This puts the H8/327 microcontroller into single chip mode. This is the correct mode for the XL403 operation.

Microcontroller I/O Ports.

Port 1

- Port 1-0 is the clock signal for the channel shift register chain 1
- Port 1-1 is the data signal for the channel shift register chain 1
- Port 1-2 is the clock signal for the channel shift register chain 2
- Port 1-3 is the data signal for the channel shift register chain 2
- Port 1-4 is the clock signal for the fader shift register chain
- Port 1-5 is the data signal for the fader shift register chain
- Port 1-6 is the input pod phase switch control signal
- Port 1-7 is the input pod line switch control signal

Port 2

- Port 2-0 is the data strobe signal for the channel shift register chain 1
- Port 2-1 is the data strobe signal for the channel shift register chain 2
- Port 2-2 is the data strobe signal for the fader shift register chain
- Port 2-3 is the local SOLO control signal
- Port 2-4 is the ISOLATE switch input
- Port 2-5 is the MUTE AUTO output
- Port 2-6 is the SOLO OUT output
- Port 2-7 is the SOLO switch input

Port 3

Port 3 is the console data bus I/O port.

Port 4

Port 4 is used for the majority of the control lines for communicating with the central control CPU.

Port 4-0 is the switch strobe line, used to initiate data transfer.

Port 4-1 is the fader strobe line, reserved for future expansion.

Port 4-2 is the channel select line. The address decoder input.

Port 4-3 is the Make up line, used to indicate that a switch has been altered since the last store operation.

Port 4-4 is the Ready line, used in conjunction with the switch strobe line for controlling data transfer.

Port 4-5 is reserved for future expansion.

Port 4-6 is the Status, or Read/ Not write line.

Port 4-7 is the valid bus output. Used to indicate to the central control CPU that a valid fader exists at the current address.

Port 5

The serial interface lines TXD and RXD are fed through resistors to the TXD and RXD busses. The XL4 serial protocol uses a 'speak only when you are spoken to' system to prevent serial bus contentions. That is, the serial bus master device decides which of the input fader units may use the bus at any particular time. At other times this bus is inactive.

For early releases of the XL4, the serial communications system is not used. It is reserved for future expansion of the XL4 facilities.

The MOTOR line is used to control the servo motor on/off state when moving faders are fitted. The line is HIGH to enable the motor.

Port 6

Port 6-0 is the input fader mode line TL0.

Port 6-1 is the input fader mode line TL1.

Port 6-2 is the input fader mode line TL2.

Port 6-3 is the time clock input.

Port 6-4 is the Pulse-width-modulated output for dynamics control which is reserved for future expansion.

Port 6-5 is the 'fader touched' input.

Port 6-6 is the 'solo clear' input.

Port 6-7 is the Pulse-width-modulated output for the fader servo.

Port 7

Port 7 is the input port for the eight Analogue-to-digital converter lines.

Port 7-0 is the fader position input.

Port 7-1 is the feedback input for the dynamic output digital-to-analogue converter which is reserved for future expansion.

Port 7-2 is the local switch chain input.

Port 7-3 is the channel switch chain 1 input.

Port 7-4 is the channel switch chain 2 input.

Port 7-5 is the channel switch chain 3 input.

Port 7-6 is the signal level sense input.

Port 7-7 is the feedback input for the fader servo digital-to-analogue converter.

Main CPU interface circuits.

Most of the automated switches on the input module and the fader board function as part of a resistor ladder. There are four of these ladders; three on the input module and one local to the fader board. Each ladder has a 5 volt reference supplied to one end while the switches are supplied with a 0 volt reference. If a switch is pressed it forms a potential divider via the resistor ladder and produces a change in the ladder output voltage. The resistor values have been chosen so that each switch will produce a different divided output voltage. This output is fed to one of the H8 microcontroller A to D inputs where the voltage level is recognised as a particular switch having been pressed.

Control of most of the automated functions on the fader board and input module is achieved using chains of 74HC4094 shift and store latches. The fader board has a four chip chain (32 bits), the input module has a three chip chain (24 bits) and a second single chip (8 bits). The data is converted to a serial bit-stream by the microcontroller and is then shifted out to the chain using the data and clock outputs of the MCU port 1. When the data has been shifted to the correct position, the strobe output of the MCU port 2 is used to latch the data into the 74HC4094 output latches. The data and clock lines are only active when an alteration is required. At all other times the chain is inactive to eliminate noise breakthrough onto the audio.

The MUTE, PHASE and LINE switches on the input module and pod are controlled more directly. Local to the switch is a discrete bi-stable flip-flop which can be toggled by the switch or by the automation. The H8 is connected to the flip-flop by one of its bi-directional ports, this allows the switch status to be monitored and over-written if required.

The SOLO switch functions in a similar way except that there is no local hardware latch. The H8 takes care of this function and also provides a drive for the indicator led. This drive is also ORed with the VCA SOLO circuits described below to control the audio solo function on the input module. When a solo is activated the H8 provides a solo clear pulse output to clear other active solos on the console; it also monitors this line so that it can be cleared by a solo being activated on a different channel.

Communication with the automation central controller is achieved via an 8 bit bi-directional latch connected to the port 3 of the H8. The automation central controller uses the status line to determine the direction of data movement and addresses the fader board via the 8 way decode boards channel select line.

Automute circuits.

The automute control signals generated by the comms module automute switches and are distributed to all the Input fader boards via the 60 way ribbon cable. These signals are active high, that is, they are high when the automute is switched on.

The local automute control is the first shift register of the fader logic chain. When a fader switch is ON in automute mode, the corresponding bit of the shift register outputs is set high.

This bit is ANDed with the related automute control signal from the centre section. When both signals are high the output of the output of the open-collector NAND gate is pulled LOW.

The eight outputs of the NAND gates are connected together to form an 'inverse OR gate'. That is, if any of the NAND gate outputs are low, the signal on the input to the inverter is LOW. The inverter turns this signal into an active HIGH signal again which is fed to the AUTOMUTE control output.

VCA Control Circuits.

The VCA control circuit has two functions, both controlled by the same section of the shift and store chain. These functions are the VCA DC voltage selection and the VCA SOLO function.

The DC voltage selection function is achieved by simply closing a DG212 CMOS switch, connecting the relevant VCA DC bus to the VCA summing buffer input. The local fader DC output is also summed to this point.

The VCA SOLO function is ANDed and inverse ORed in the same way as the automute system to produce the SOLO LINE which controls the input module audio solo switching.

The status of the ISOLate switch is monitored by the H8 at all times and if the switch is active it opens all the DG212 CMOS switches and deactivates any VCA SOLOs, again via the shift and store chain.

Motorised Fader and Analogue Circuits.

The input VCA board is capable of supporting an "OUTBOARD ELECTRONICS LIMITED" motorised fader. The fader position is sensed by the H8 via one of its A to D converters and the fader servo system can be driven by a PWM output from the H8 which is fed to it via a simple low pass filter.

The time clock signal is used to adjust the timing of fader movements. If this signal is not present the MCUs default to 20ms/Frame. The central control unit only needs to generate this signal if the timing requires adjustment.

Should the timing signal cease after being used, the fader timing will remain at the last used timing value until the signal re-appears or the system is reset.

Global motor off is a signal used to disable all motorised faders should the central control unit detect a problem. It should normally be HIGH (motors on).

The remaining analogue circuits are the AC to DC converters which take the SENSE signals from the module, which are the pre and post fader signal levels, and convert them into a DC level which can be read by the H8's A to D converters. This section is available for use in future updates to the system.

5. Group VCA Fader.

The 413 group VCA fader block is made up from 3 parts as follows:-

- 1 off 458 group VCA master mother board
- 12 off 413 group VCA master fader board
- 12 off Motorised fader servo board

The 458 group VCA master mother board is the heart of this section, providing a central point for much of the automation cabling as well as a large amount of active circuitry. This is mostly controlled by an H8 microcontroller. The 413 group VCA master fader board and motorised fader servo boards are connected to the group VCA master mother board by 12 ribbon cables.

The circuit functions of the VCA fader block can be split as follows:-

Microcontroller address decoding.

Automated switch functions.

Fader servo drive and position.

VCA fader DC control.

Group VCA master fader board.

Fader servo board.

Microcontroller Address Decoding.

A. Automation central controller.

The address decoding for the automation central controller interface is on-board and unlike the input fader boards it requires two addresses, 0 and 1.

The decoding therefore only works on the 6 upper bits of the address bus, the lowest address line is fed to the H8 to select which valid address is current. Address 0, with A0 LOW is the switch control address and address 1, with A0 HIGH is the fader control address.

The address decoding on the other address lines (A1 through A6) enables the H8 Interface when they are all LOW.

B. Local Bus.

The local, or internal address bus are labelled CL0 to CL7 with CL4 & 5 not used. CL6 & 7 are used to select the various address banks or circuit functions which then decode the low order addresses as required.

The VCA_STB lines are produced by IC18 when CL6 & 7 are both LOW. These lines are used to strobe the sample & hold circuits when moving the faders. This chip also decodes the motor off control bit address lines M_ENA1 & 2.

The F_STB lines are produced by IC17 when CL6 is HIGH & CL7 is LOW. These lines are used to strobe the group VCA master fader board circuits (XL413).

When CL6 is LOW and CL7 is HIGH the data bus is latched into IC20. This is the D to A converter latch. The outputs from this latch drive the D to A converter, IC21.

When CL6 & 7 are both HIGH the switch register decoder is enabled (IC36). This chip further decodes CL0-2 to enable the switch buffers IC30-38.

Automated switch functions.

Automated switches on the centre section modules and group VCA master faders are latched locally by discrete bi-stable flip-flops. These can be written to, or read by, the H8 via bi-directional buffers IC30-38.

The direction of data flow in this case is determined by the READ/NOT WRITE line from the H8 IC15 pin 49.

During READ operations the settings of the switch latches are read into the H8 and the switch status is unaffected. During WRITE operations the outputs of the buffers override the switch settings and force the switch latches into the state required by the received data.

Fader servo drive and position.

The motorised faders are all controlled by the H8. It uses a 5 volt reference, derived from the 5 volt rail, to send DC control voltages which move the faders and receive DC sense voltages which define the actual fader position.

All the faders have a position track which is connected to the 5 volt reference at one end and to 0VD at the other. The 12 wiper outputs are multiplexed by CMOS switches IC27, 28 & 29 onto 4 A to D converters which are internal to the H8 microcontroller. The multiplexing is controlled by the H8 via latch IC26. This IC and IC27 are also used to control the fader motor ON/OFF status. The H8 can monitor and store the position of the faders by the digital codes produced from its A to D converters.

To drive the faders the H8 addresses a discrete current multiplying 8 bit DAC. This is multiplexed 12 ways and feeds sample and hold circuits which construct smooth DC control voltages.

The current reference for the DAC is generated from the 5 volt reference by the Op-Amp IC23b. The reference may be adjusted using P1 so that it is calibrated to match the A to D converters on the H8 microcontroller. This adjustment sets the top or boost end of the faders.

The output of the DAC is also a current. This is converted into a voltage by IC23a. and the output fed to all the sample and hold circuits.

The 12 sample and hold circuits are identical consisting of a voltage follower which drives the fader servos. On the input to the voltage follower is the "hold" capacitor which is fed through a CMOS switch. When the DAC output has settled to the desired value the CMOS switch is closed, charging the capacitor to the required level. When the CMOS switch opens the capacitor will maintain the voltage for a sufficient period to allow all 12 channels to be updated sequentially without noticeable "droop".

When the faders are not under servo control moving the faders manually will charge the "hold" capacitor to the new position value. This is to avoid unwanted fader "kick" movements when the servos are required to operate again. This is achieved by a 1M "bleed" resistor feeding the capacitor from the fader position track wiper.

VCA Fader DC control.

The VCA system requires a stable and absolute reference voltage. This is established by zener diode D6 before being buffered and trimmed to 6 volts by IC13a and P2. This voltage is used to provide a VCA DC reference for all the fader tray. The 12 centre faders run from an inverted form of this which is biased up by 0.6 volts. This means that the fader wipers can swing from +0.6 volts to -5.4 volts. P3 adjusts this bias. The faders are centre tapped to 0 volts at the 0dB position to give accurate positioning.

The 12 fader wipers are fed via CMOS switches to inverting buffers which drive the VCA busses. These are fed to the input VCA faders and group modules. If the console is linked and used as the "slave" the SLAVE_IN line opens the CMOS switches disconnecting the faders from the busses. Incoming voltages are then fed from the "master" console to control the VCA busses via the DC link pcb. If our console is the "master" the buffered VCA busses are fed out to the slave via the same DC link pcb.

When consoles are linked the solo clear system is also linked by a time limited export and import buffer system created around IC39.

Group VCA master fader board.

The fader board is used largely to mount the switches and link signals to the servo board however there is some active circuitry. Two bi-stable flip-flops latch the solo and mute switches. These are toggled by momentary connection to a capacitive charge or via automation. The VCA solo is buffered here to drive the busses via a low-pass filter. For console linking the VCA solo busses are also ORed in at this point.

Fader servo board.

The servo board consists of the servo control system, the motor drive and the motor off touch sensor.

The fader position voltage is buffered and feed to the H8 A to D converters. The incoming position control voltage is processed by an inverting 3Hz low-pass filter. It is then compared with the buffered position voltage by a dual non-linear comparitor which drives the motor. Any difference between the required fader position and the actual fader position results in a voltage driven onto the motor.

The motor drive is provided by a balanced opp-amp and transistor output stage which to save current draw is predominantly class B.

The touch sensor circuit uses body capacitance to slow a high impedance CMOS signal, The output from this circuit is fed to the H8 microcontroller and to a FET which can disconnect the motor drive.

NOTE: the motor is not intended to be driven for prolonged continuous periods. If this is allowed to happen the motor and the motor drive circuit will become very hot and may be permanently damaged.

SCHEMATIC DIAGRAMS

XL403-1.DGM	XL4 VCA FADER
XL403-2.DGM	XL4 VCA FADER
XL403-3.DGM	XL4 VCA FADER
XL4-FAD1.DGT	FADER SIGNAL DECODING
XL4-GRP.DGT	XL413 GROUP FADERS
XL4GFM1.DGM	V.C.A. BUS DRIVERS
XL4GFM2.DGM	SAMPLE & HOLD \ REFERENCE
XL4GFM3.DGM	GP FADER CONNECTORS
XL4GFM4.DGM	C.P.U.
XL4GFM5.DGM	FADER SWITCHING
XL4GFM6.DGM	MODULE SWITCHES
XL4-AUSW.DGT	AUTOMATION SWITCH SUB-BOARD
XL4-LINK.DGT	FADER PSU & PROCESSOR LINK
XL456.SCH	DC LINK PCB (AUTOMUTES)
XL456.SCH	DC LINK PCB (VCA & REMOTE)
XL456.SCH	DC LINK PCB (SOLO & CONN'S)
XL4-MIDI	MIDI FILTER & RS232
SERVO.DGM	SERVO PCB

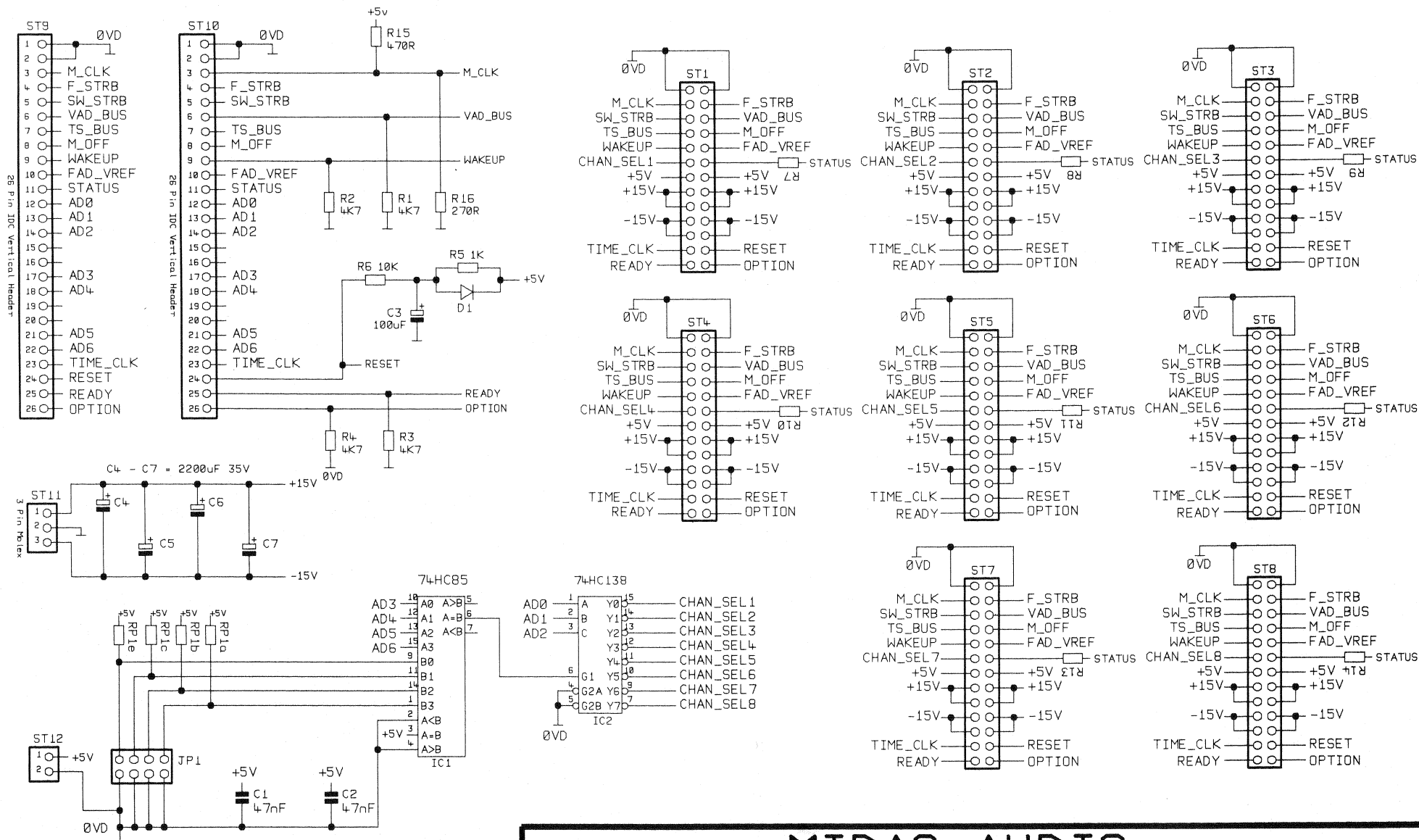

MIDAS AUDIO

Drawn: DGT	Checked:	XL403	FADER SIGNAL DECODING	1 OF 1
BOARD No. B2794 iss 3		DWG No. XL4_FAD1.DGT	DWG. ISSUE: 5	DATE: 6.Sept.95

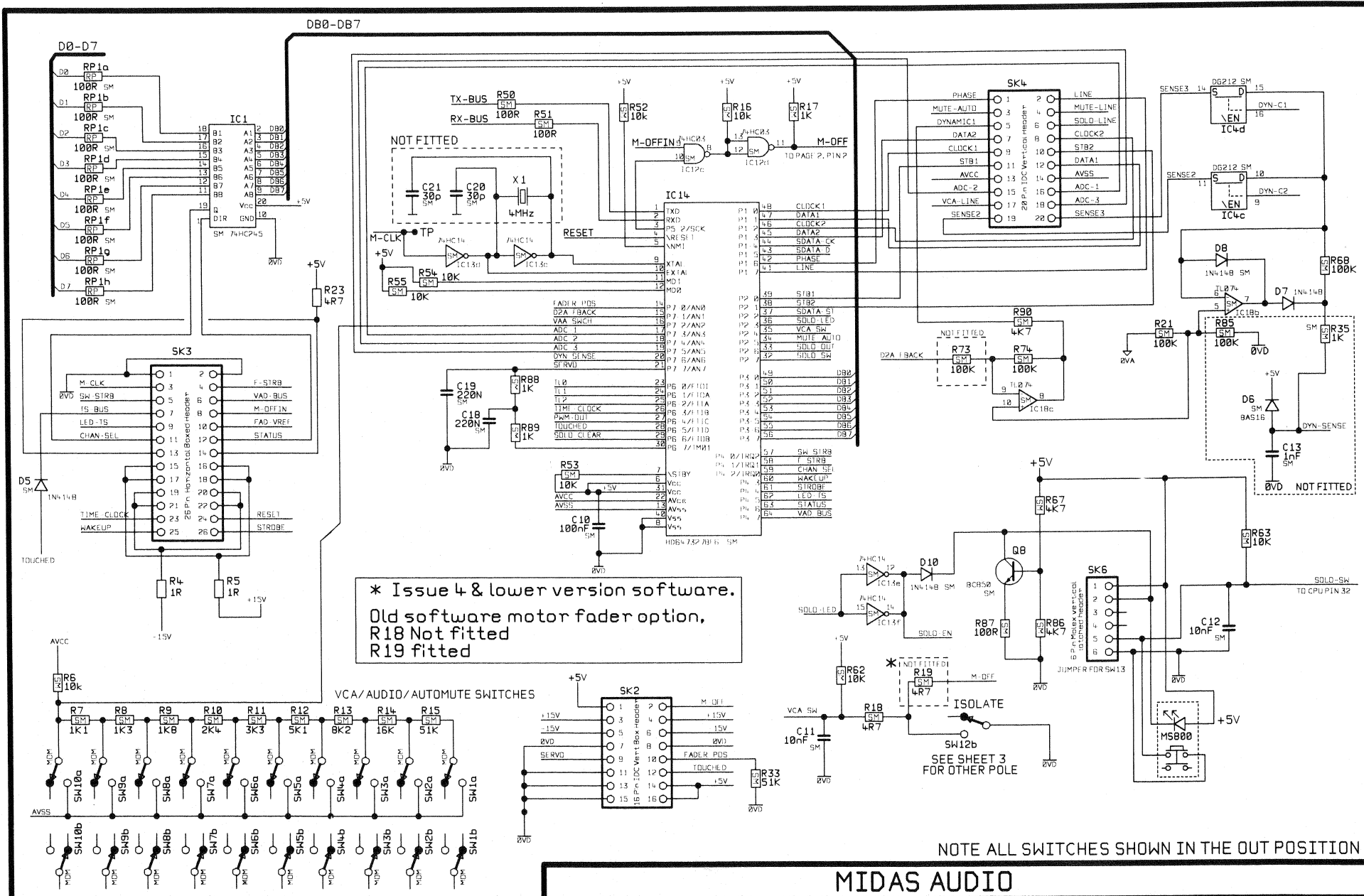

* Issue 4 & lower version software.
 Old software motor fader option,
 R18 Not fitted
 R19 fitted

NOTE ALL SWITCHES SHOWN IN THE OUT POSITION

MIDAS AUDIO

Drawing xl403_02.dgm Drawing xl403_03.dgm ignorelayers 15 17	Drawn: J.R.C Checked: A.C	UNIT XL403	XL4 VCA FADER	1 OF 3
BOARD No. B2890 ISSUE 2	DWG No. XL403_1.DGM	SHEET ISS: 4	DATE: 27.8.96	

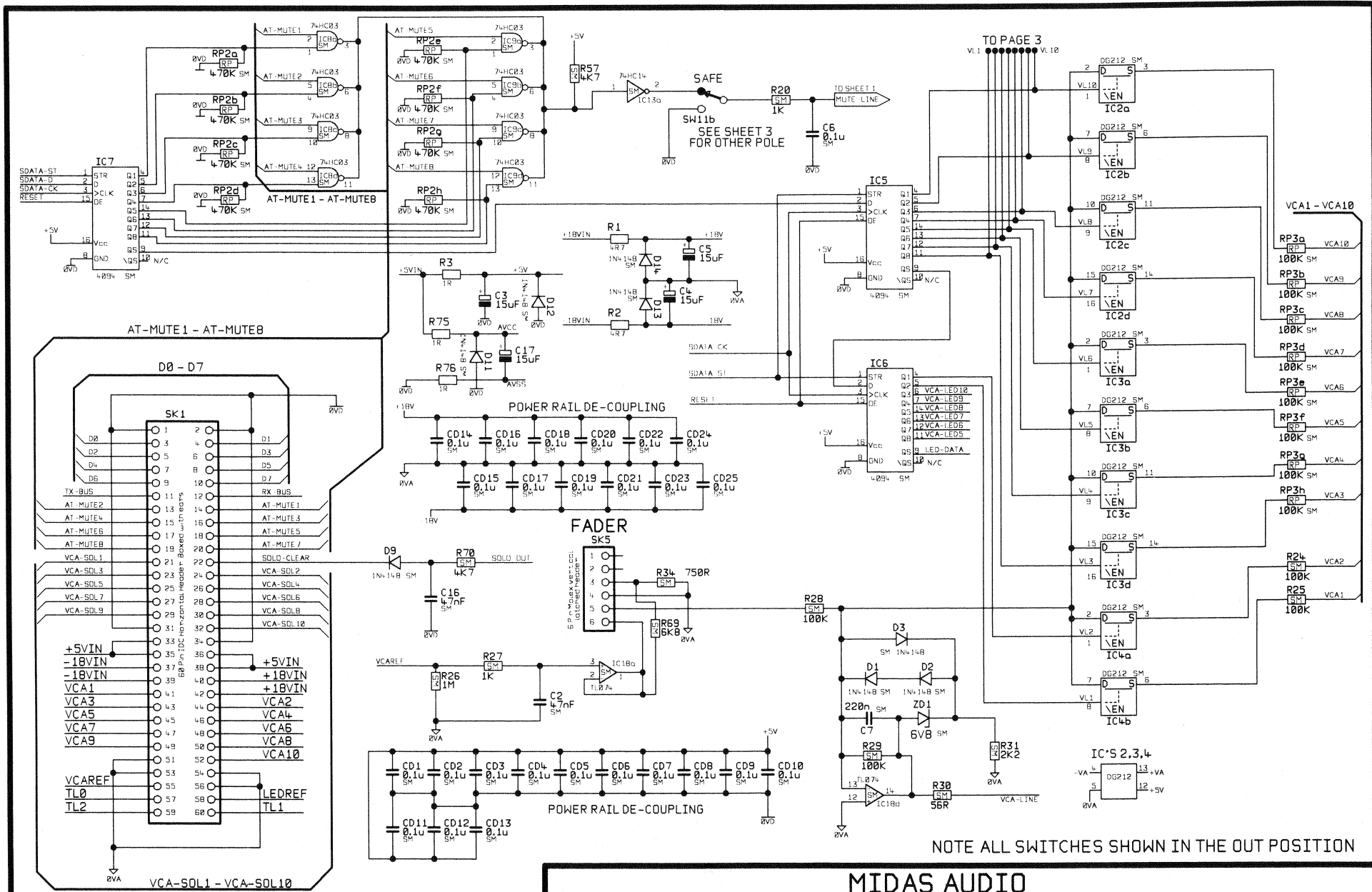

NOTE ALL SWITCHES SHOWN IN THE OUT POSITION

MIDAS AUDIO

Parent XL403_01.DGM Peer xl403_03.dgm	Drawn: J.R.C	Checked: A.C	UNIT XL403	XL4 VCA FADER	2 OF 3
ignorelayers 15 17	BOARD No. B2890 ISSUE 2	DWG No. XL403_2.DGM	SHEET ISS: 4	DATE: 27.8.96	

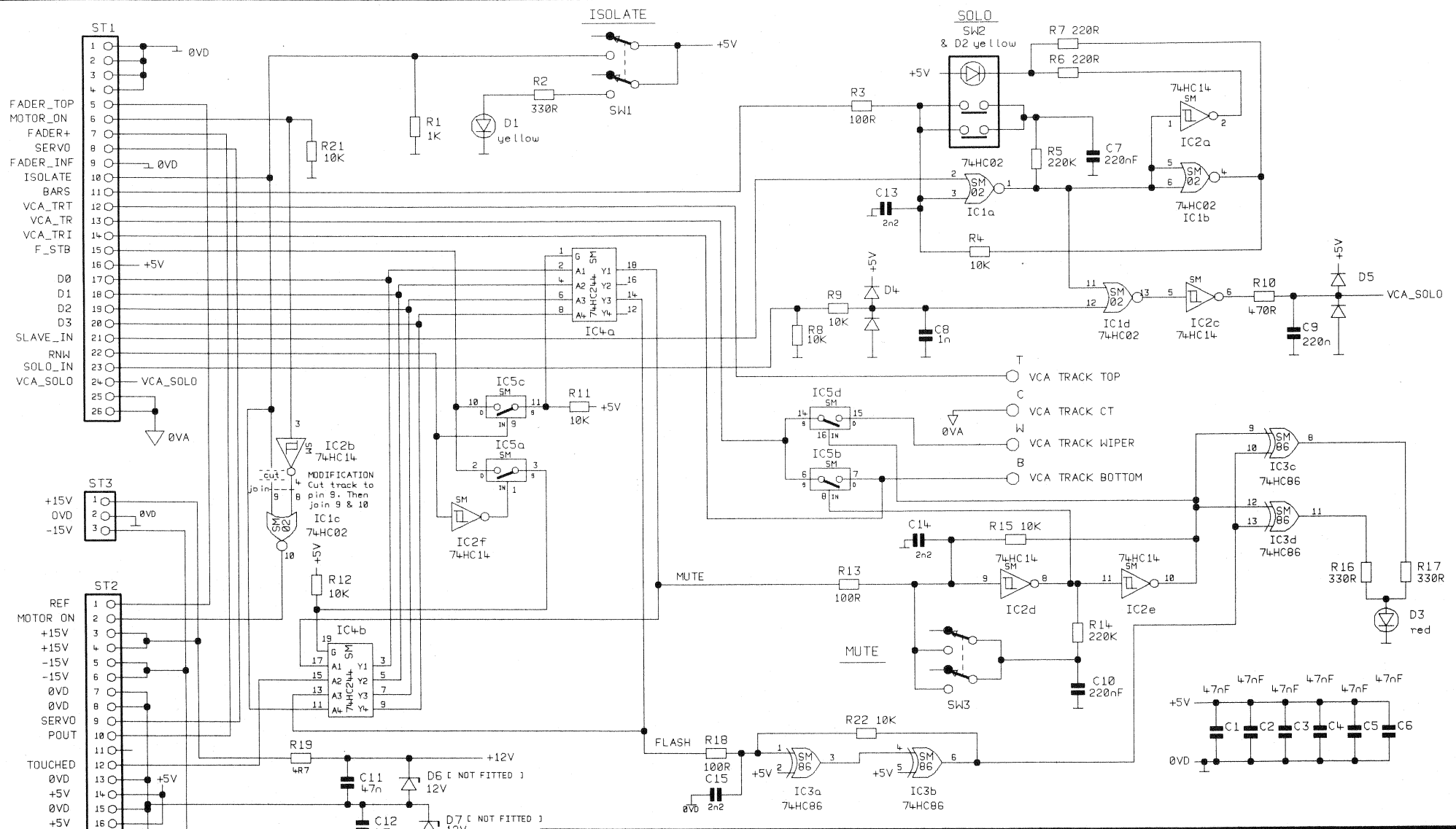

MIDAS AUDIO

Drawn: DGT	Checked: A.C	XL413 GROUP FADERS	1 OF 1
------------	--------------	--------------------	--------

MOD T.K.GILL	BOARD No. B2797 iss 3	DWG No. XL4_GRP.DGM	DWG. ISSUE: 7	DATE: 27.8.96
--------------	-----------------------	---------------------	---------------	---------------

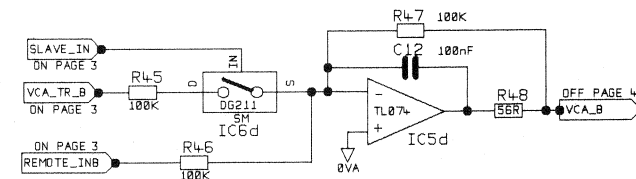
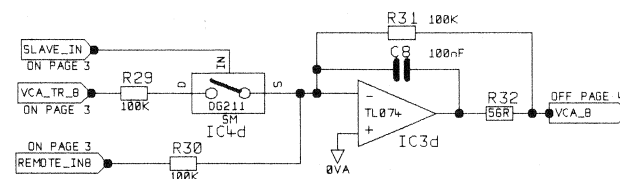
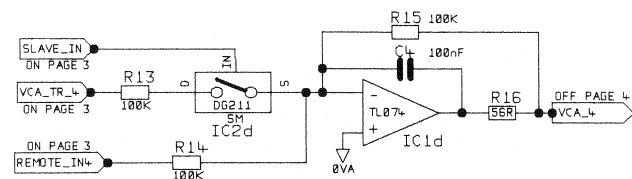
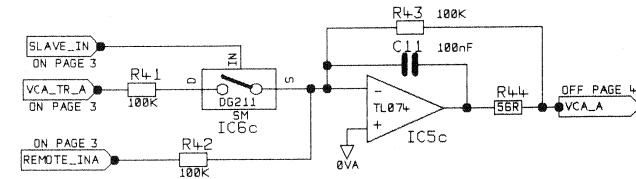
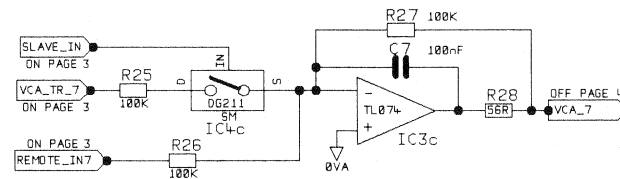
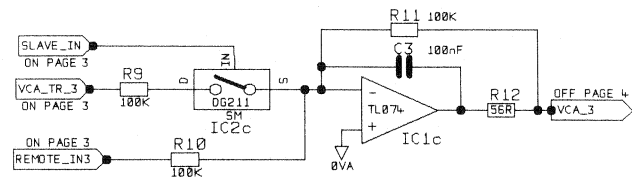
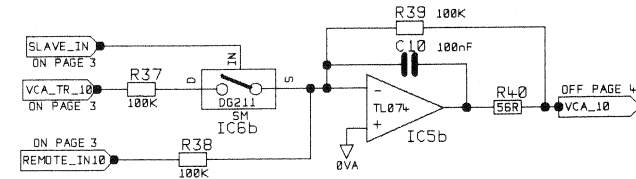
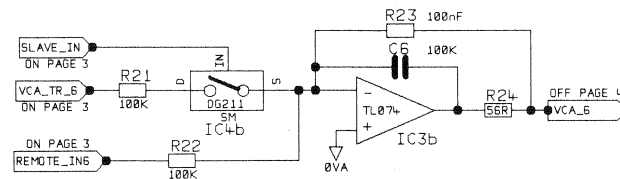
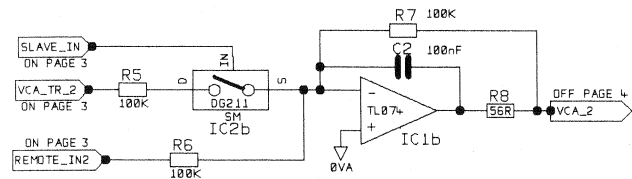
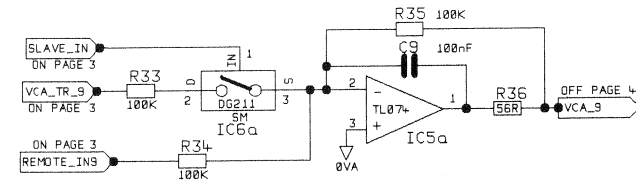
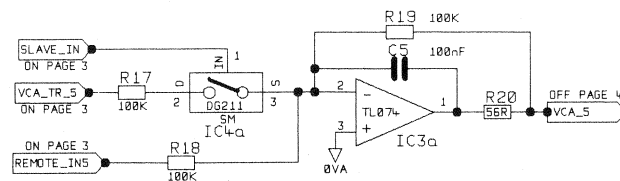
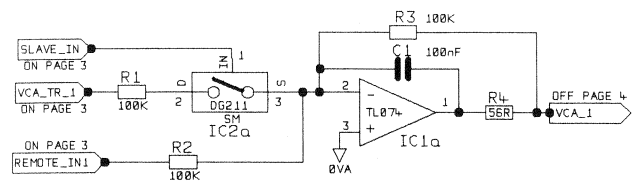

1 TO 4

5 TO 8

9 TO 12

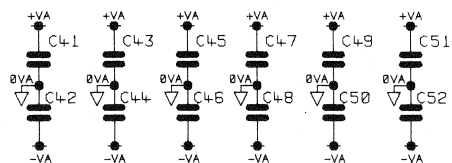

ALL 47nF

ALL CAP'S CERAMIC

MIDAS AUDIO

Drawn: T.K.G	Checked: A.C	UNIT XL458	V.C.A BUS DRIVERS	1 OF 6
BOARD No. B2791 IS2		DWG No. XL4GFM1.DGM	DWG. ISSUE: 3	DATE: 27.08.96

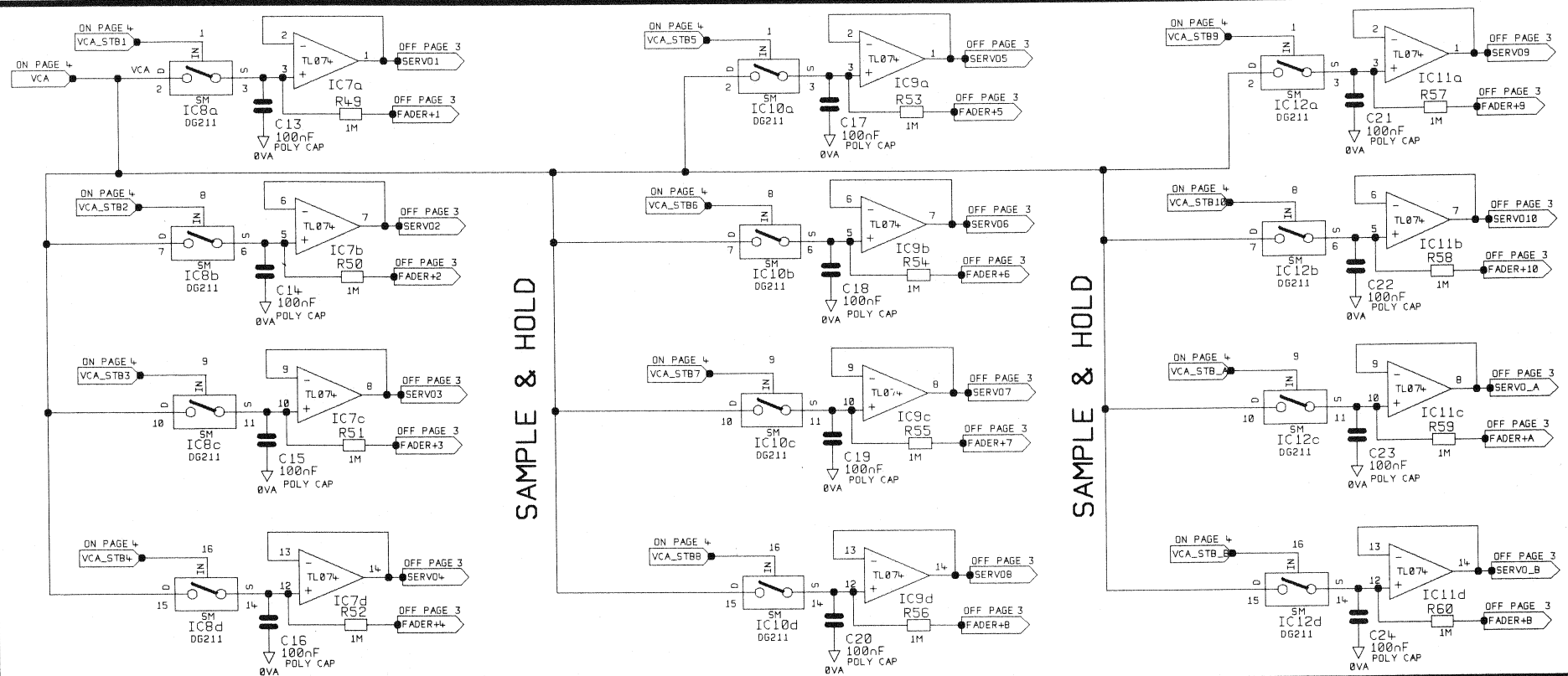

SAMPLE & HOLD

SAMPLE & HOLD

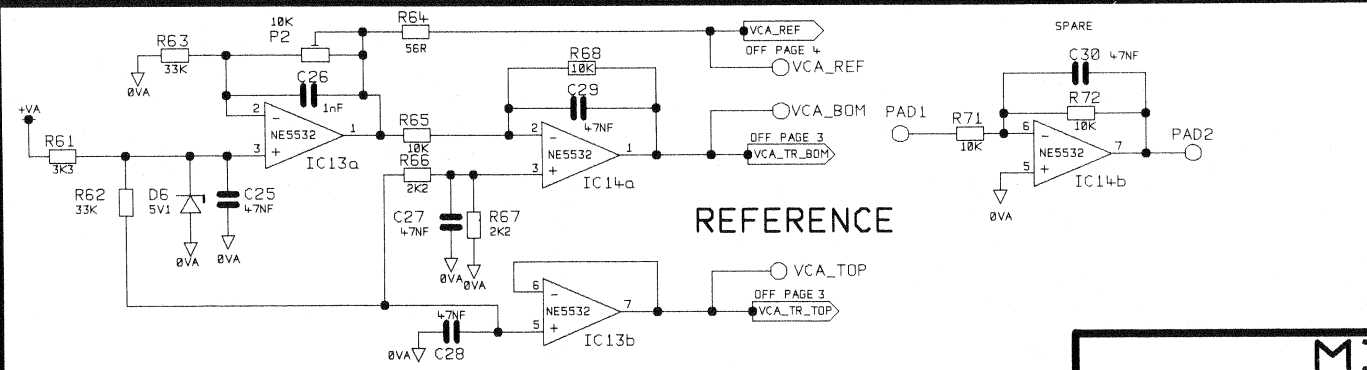

REFERENCE

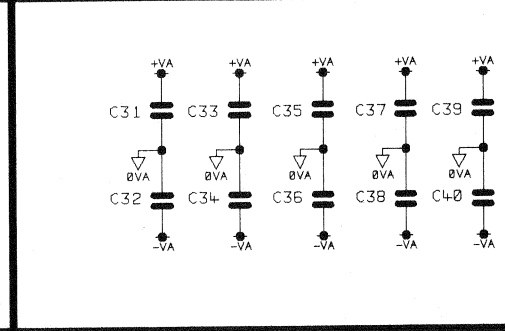

MIDAS AUDIO

Drawn: T.K.G	Checked: A.C	UNIT XL458	SAMPLE & HOLD\REFERENCE	2 OF 6
BOARD No. B2791 IS2		DWG No. XL4GFM2.DGM	DWG. ISSUE: 3	DATE: 27.08.96

ST1 TO 12 RIBBON CABLE TO GROUP VCA'S

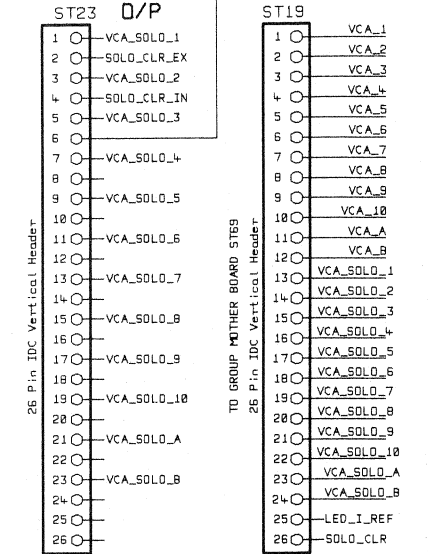
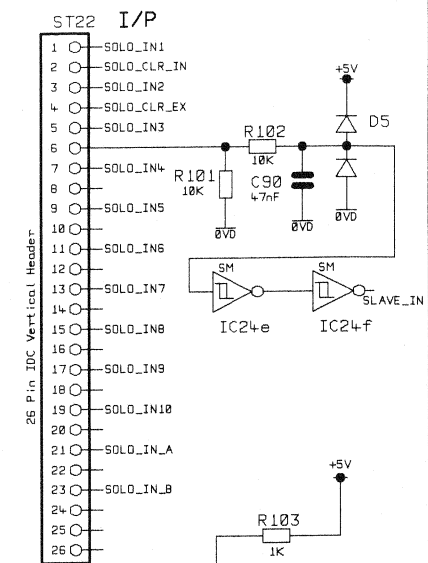
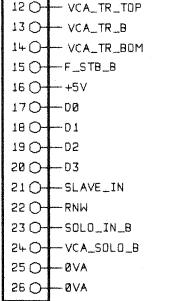
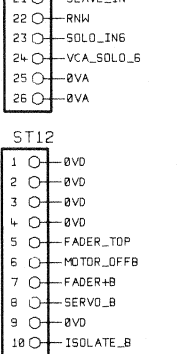
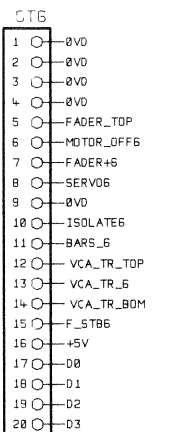
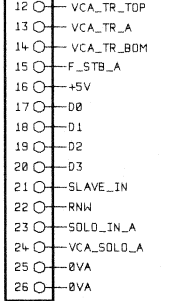
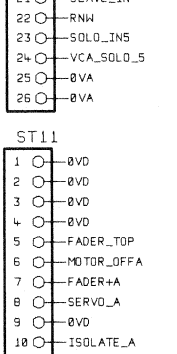
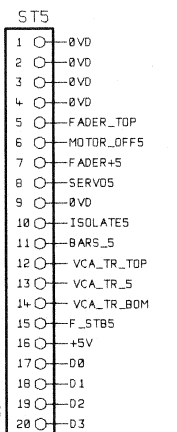
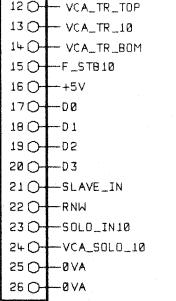
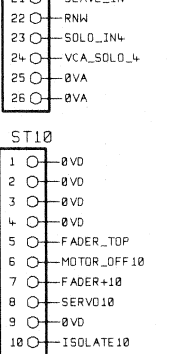
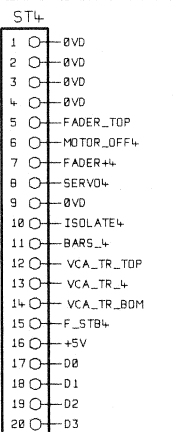
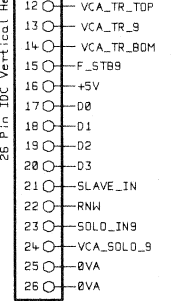
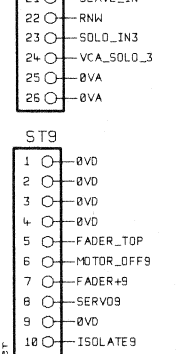
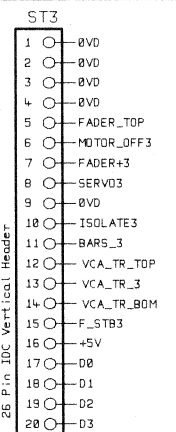
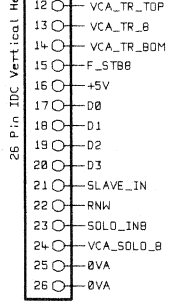
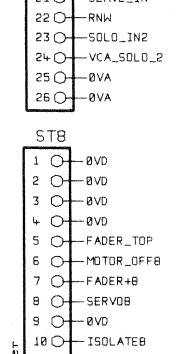
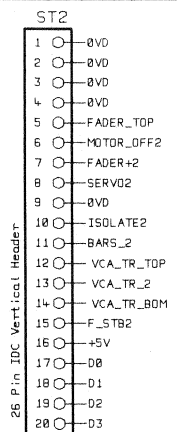
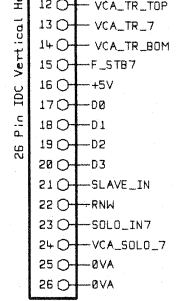
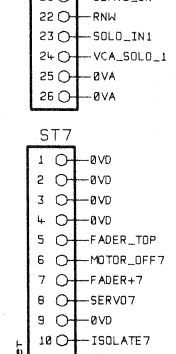
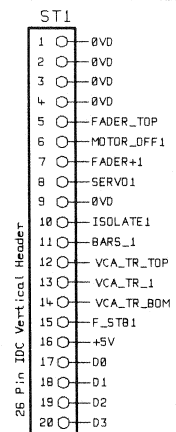
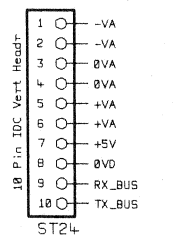
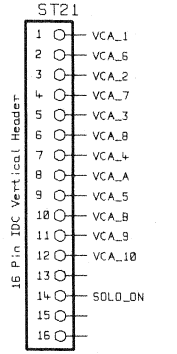
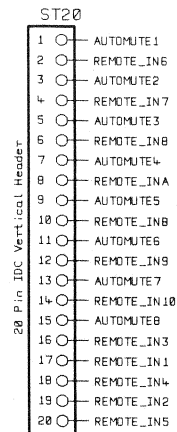

MIDAS AUDIO

Drawn: T.K.G	Checked: A.C	UNIT XL458	GP FADER CONNECTORS
BOARD No. B2791 IS2	DWG No. XL4GFM3.DGM	DWG. ISSUE: 3	DATE: 27.08.96

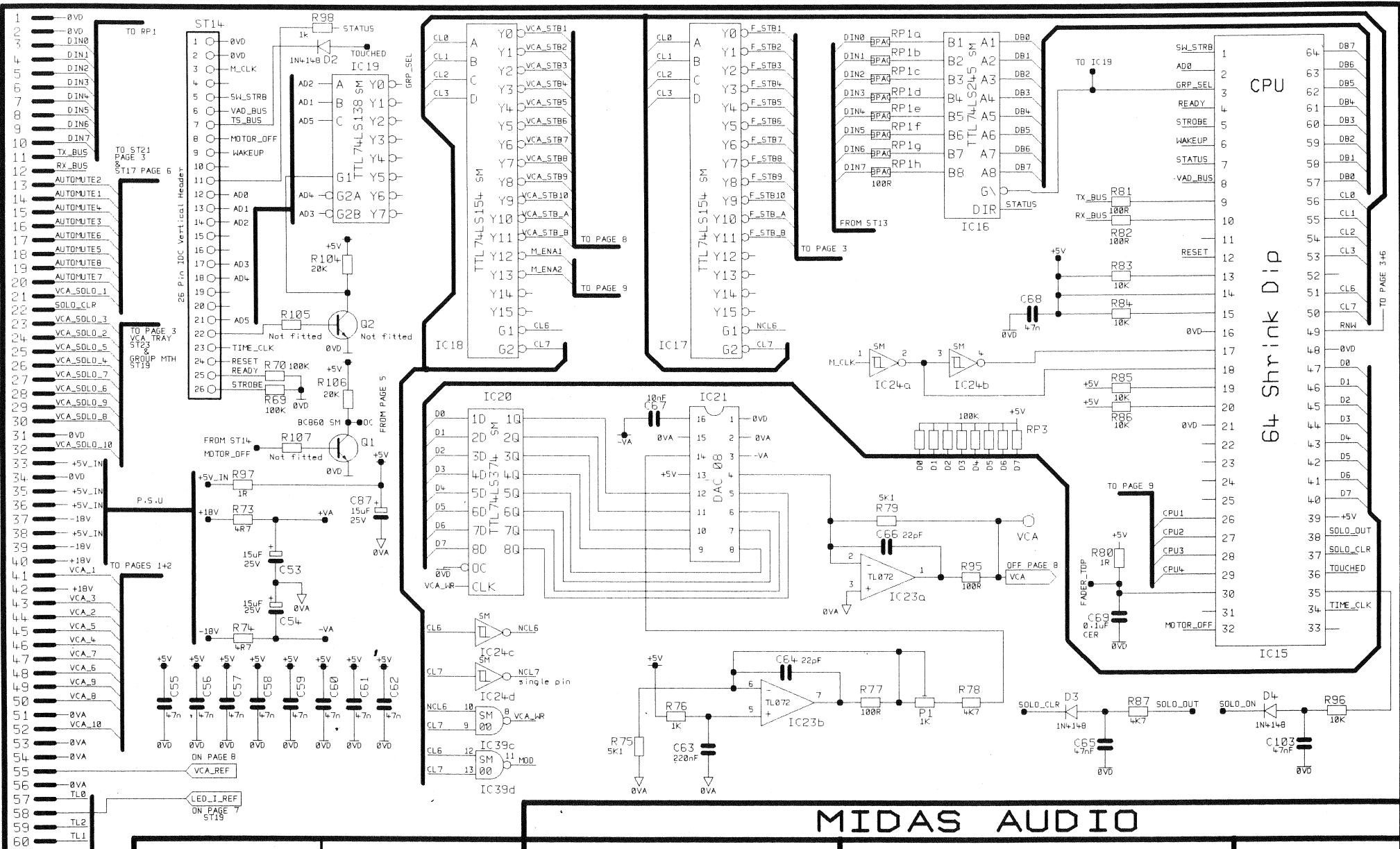

MIDAS AUDIO

Drawn: T.K.G	Checked: A.C	UNIT XL458	C.P.U
BOARD No. B2791 IS2	DWG No. XL4GFM4.DGM	DWG. ISSUE: 3	4 OF 6
DATE: 27.08.96			

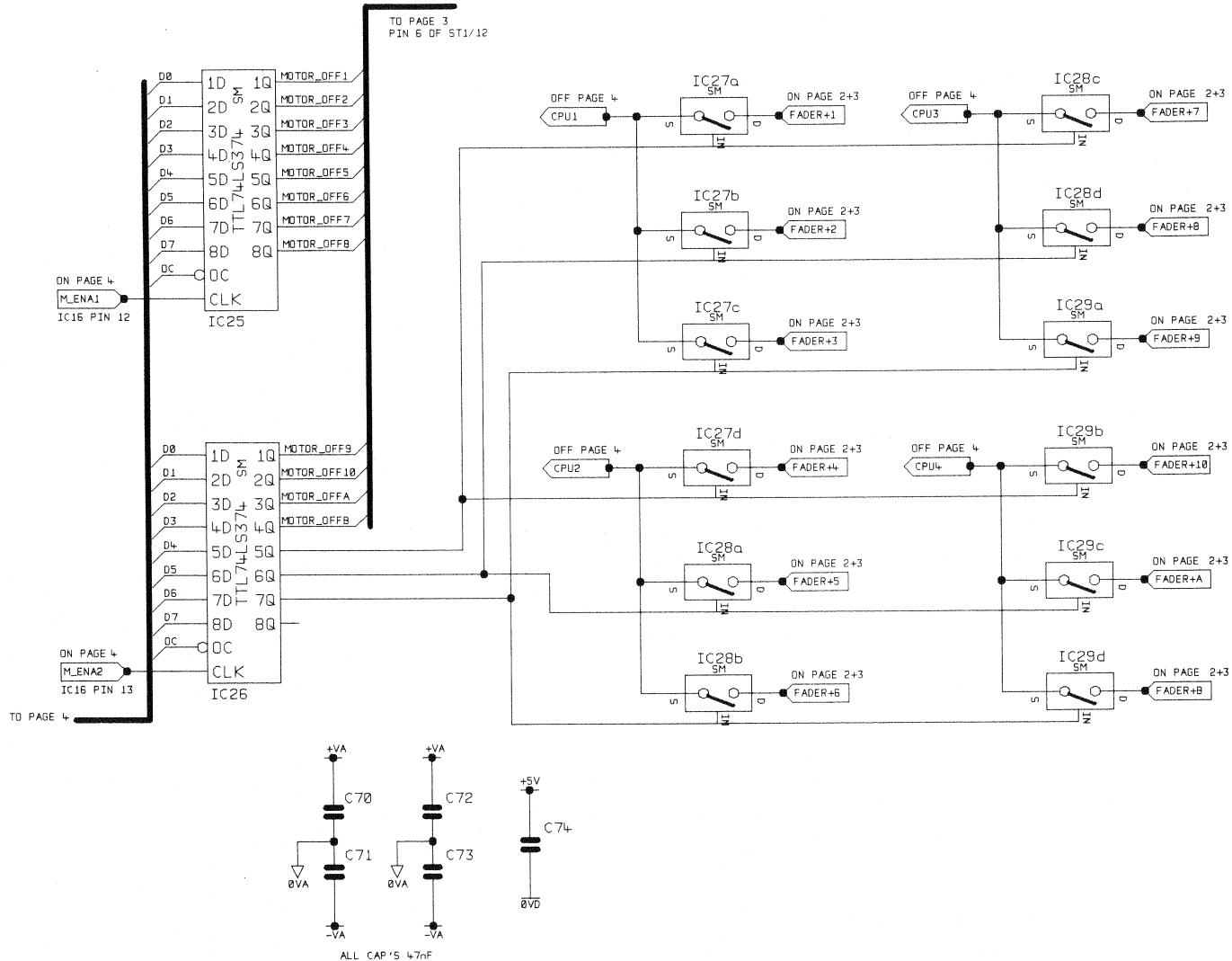

MIDAS AUDIO

Drawn: T.K.G	Checked: A.C	UNIT XL458	FADER SWITCHING	5 OF 6
BOARD No. B2791 IS2	DWG No. XL4GFM5.DGM	DWG. ISSUE: 3	DATE: 27.08.96	

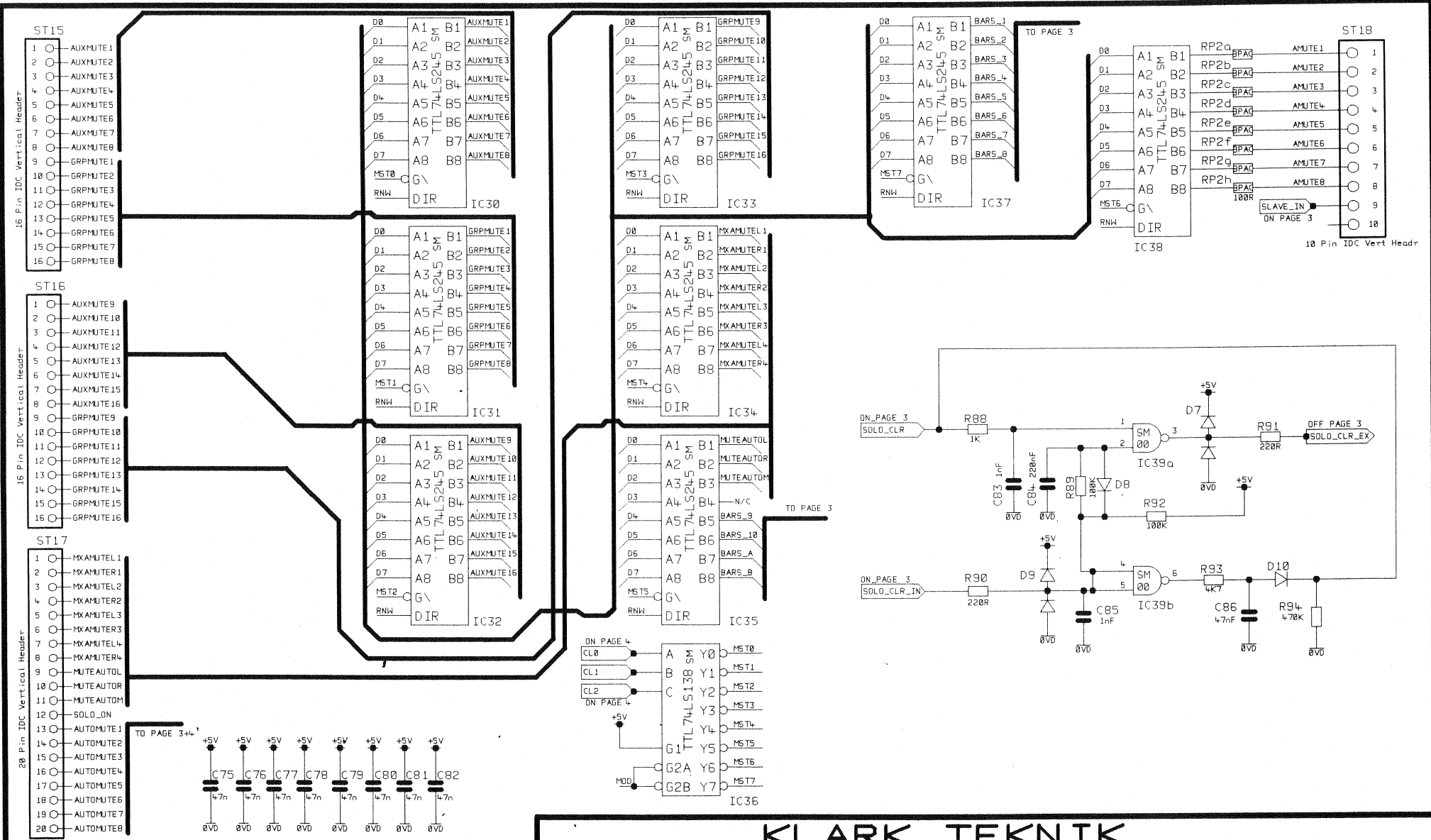

KLARK TEKNIK

Drawn: T.K.G	Checked: A.C	UNIT XL458	MODULE SWITCHES	6 OF 6
BOARD No. B2791 IS2		DWG No. XL4GFM6.DGM		DWG. ISSUE: 3
DATE: 27.08.96				

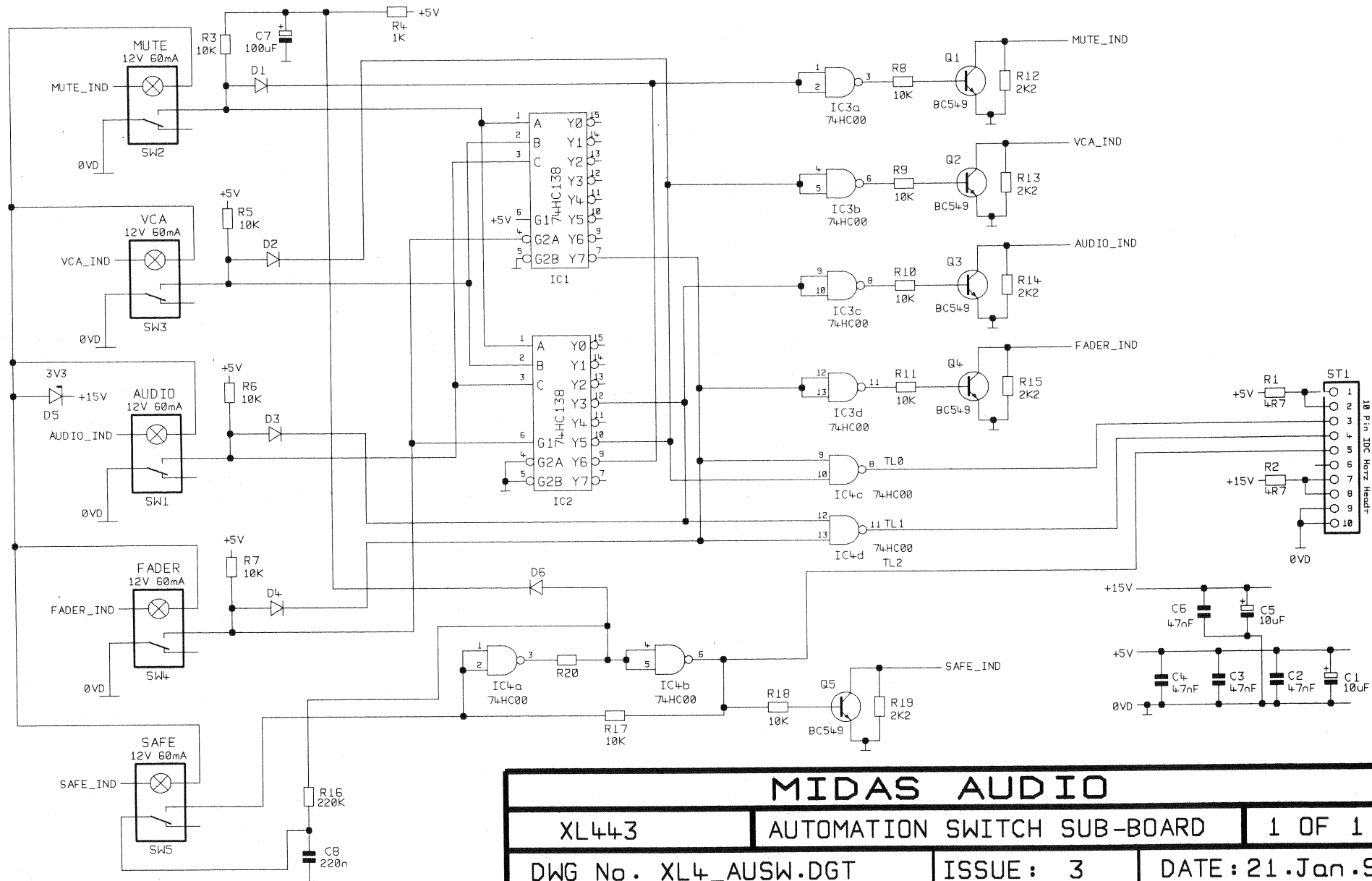

MIDAS AUDIO		
XL443	AUTOMATION SWITCH SUB-BOARD	1 OF 1
DWG No. XL4_AUSW.DGT	ISSUE: 3	DATE: 21.Jan.95
BOARD No. B2796 issue 2	Drawn: DGT	Checked:

TO FADERS

TO FADERS

TO FADER DECODE

ST2 TO OUTBOARD PROCESSOR

IC1 IS SOCKETED & ONLY FITTED ON NONE AUTOMATION CONSOLES

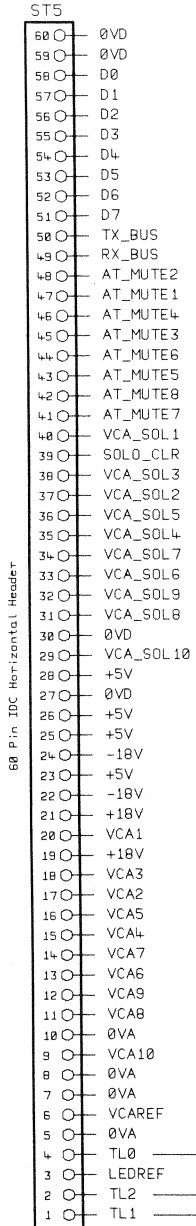
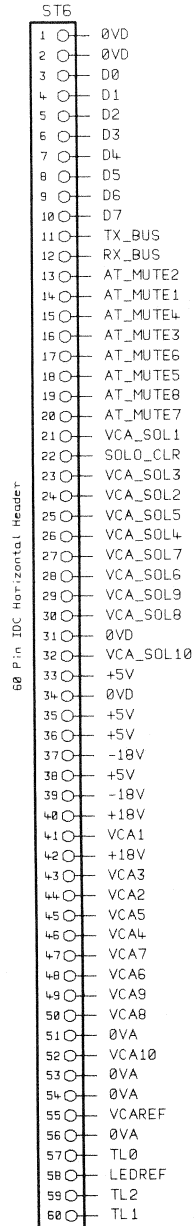

ST1.7 & 101 NOT FITTED HAND WIRED

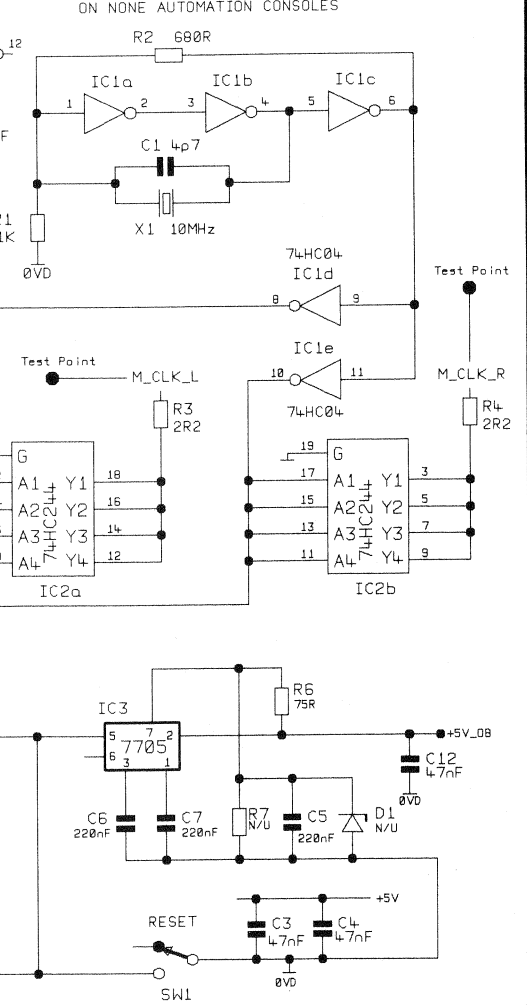
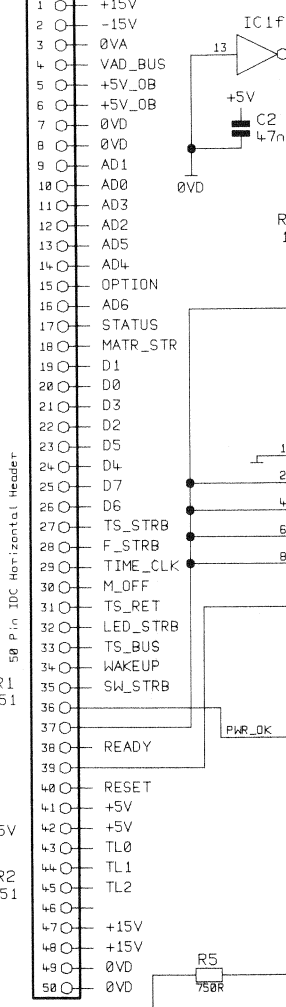
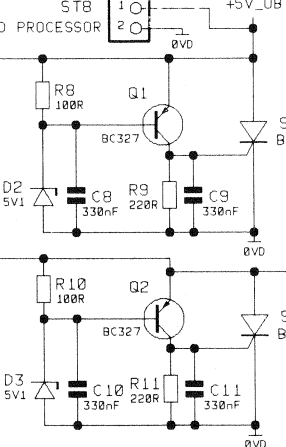
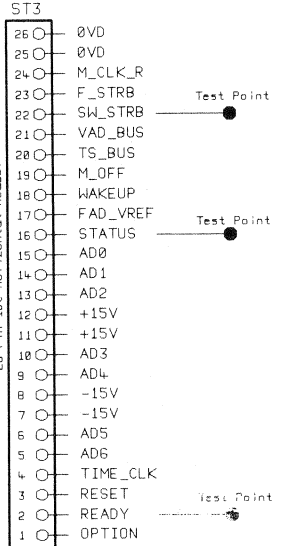
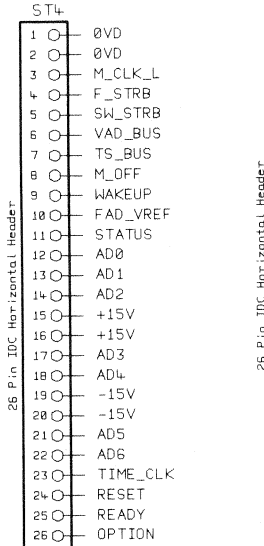
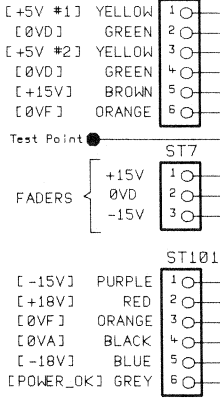

MIDAS AUDIO

XL443	FADER PSU & PROCESSOR LINK	1 OF 1
DWG No. XL4_LINK.DGT	ISSUE: 7	DATE: 23.8.96
BOARD No. B2795 IS3	Drawn: DGT	Checked: A.C

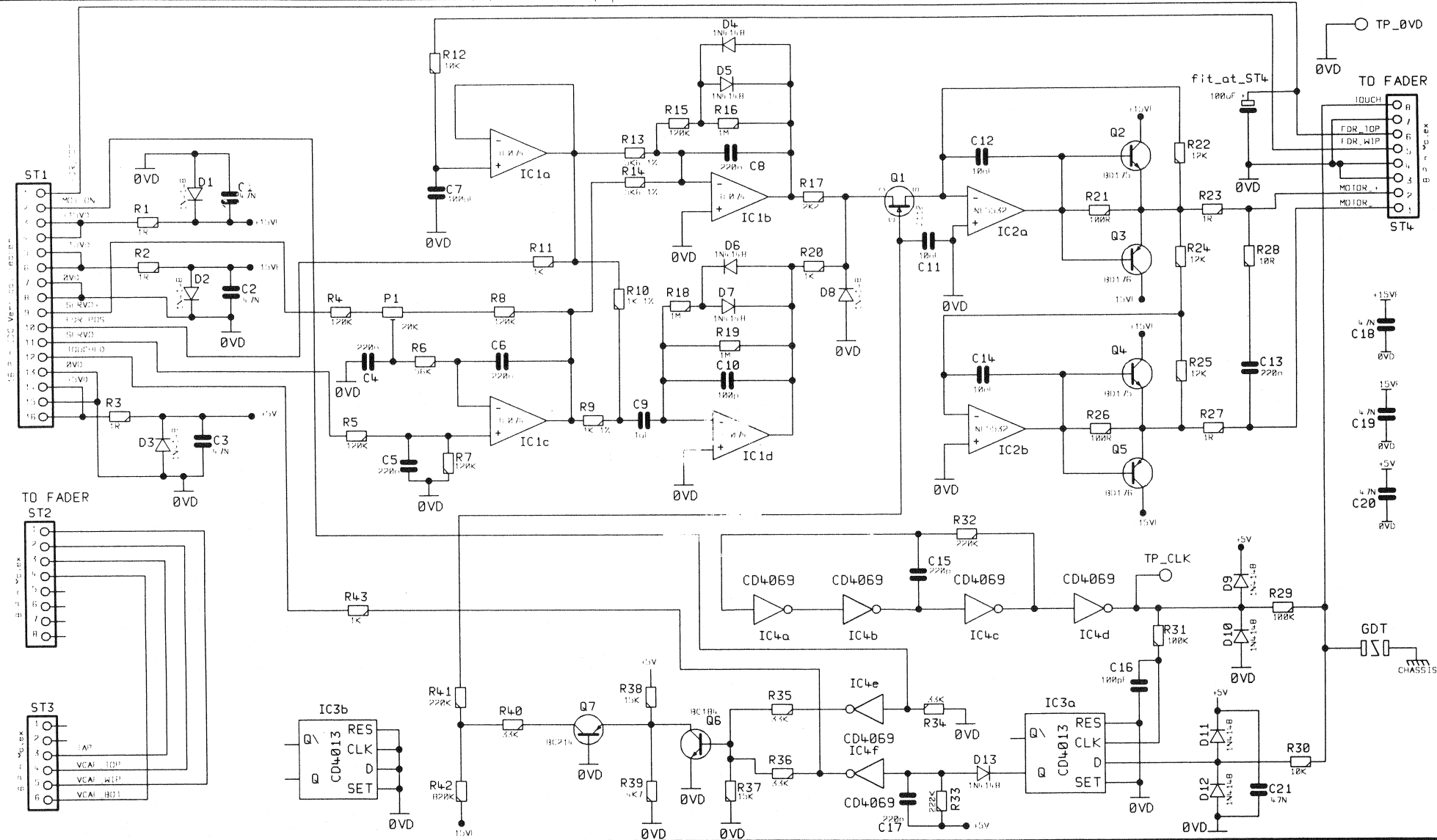

MIDAS AUDIO

Drawn: KSD	Checked: TKG-AC	UNIT XL4	SERVO PCB
BOARD No. B2886 IS2	DWG No. B2886IS2.DGM	ISSUE: 2	1 OF 1
		DATE: 23.8.96	

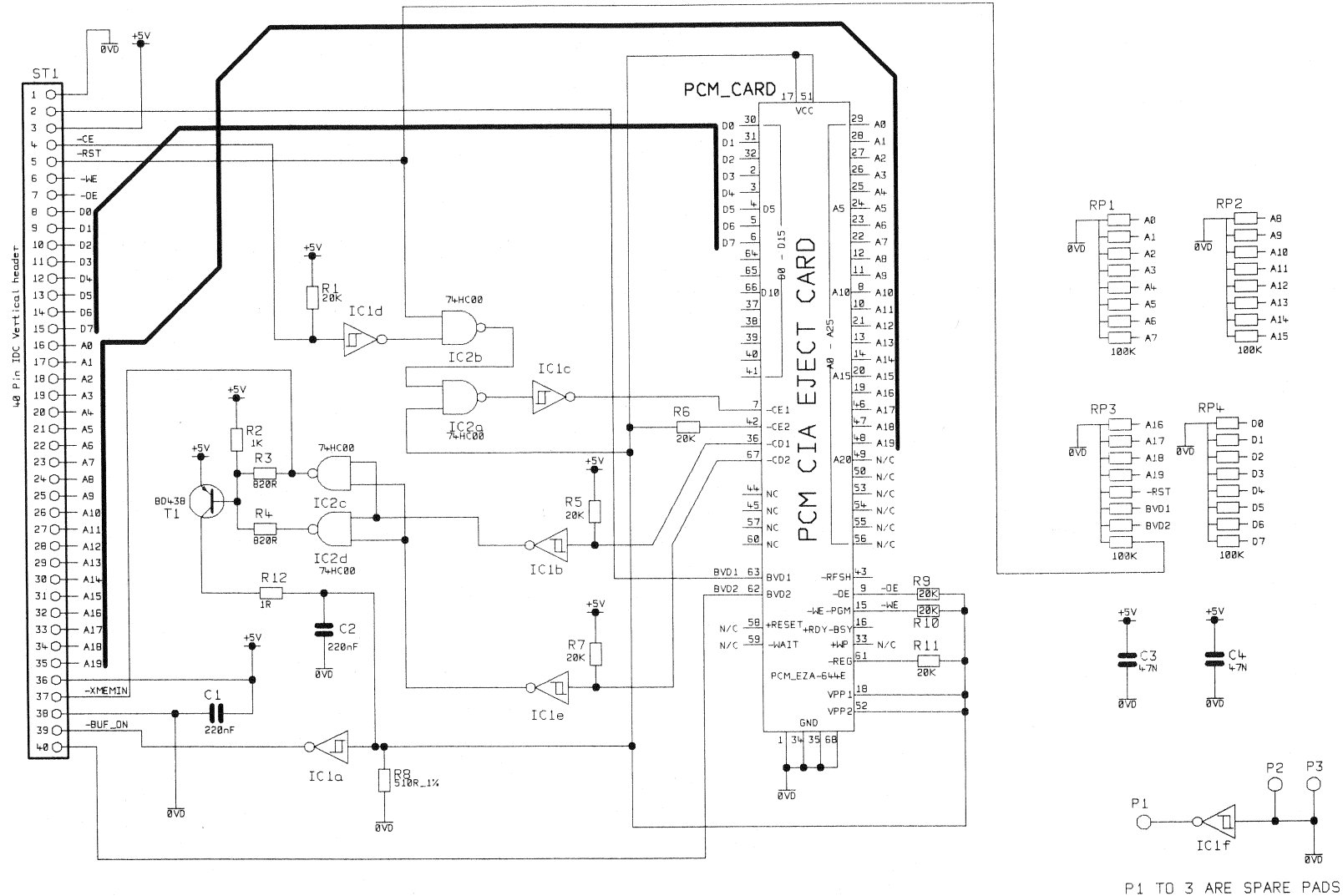

MIDAS AUDIO

Drawn: T.K.G	Checked: E.L	UNIT XL4	PCM CARD	1 OF 1
BOARD No. B2902 IS1	DWG No. XL4_PCM1.DGM	ISSUE: 1	DATE: 13.3.96	